

VS

MONTAGEHANDLEIDING - ASSEMBLY MANUAL - MONTAGEANLEITUNG - MANUEL DE MONTAGE

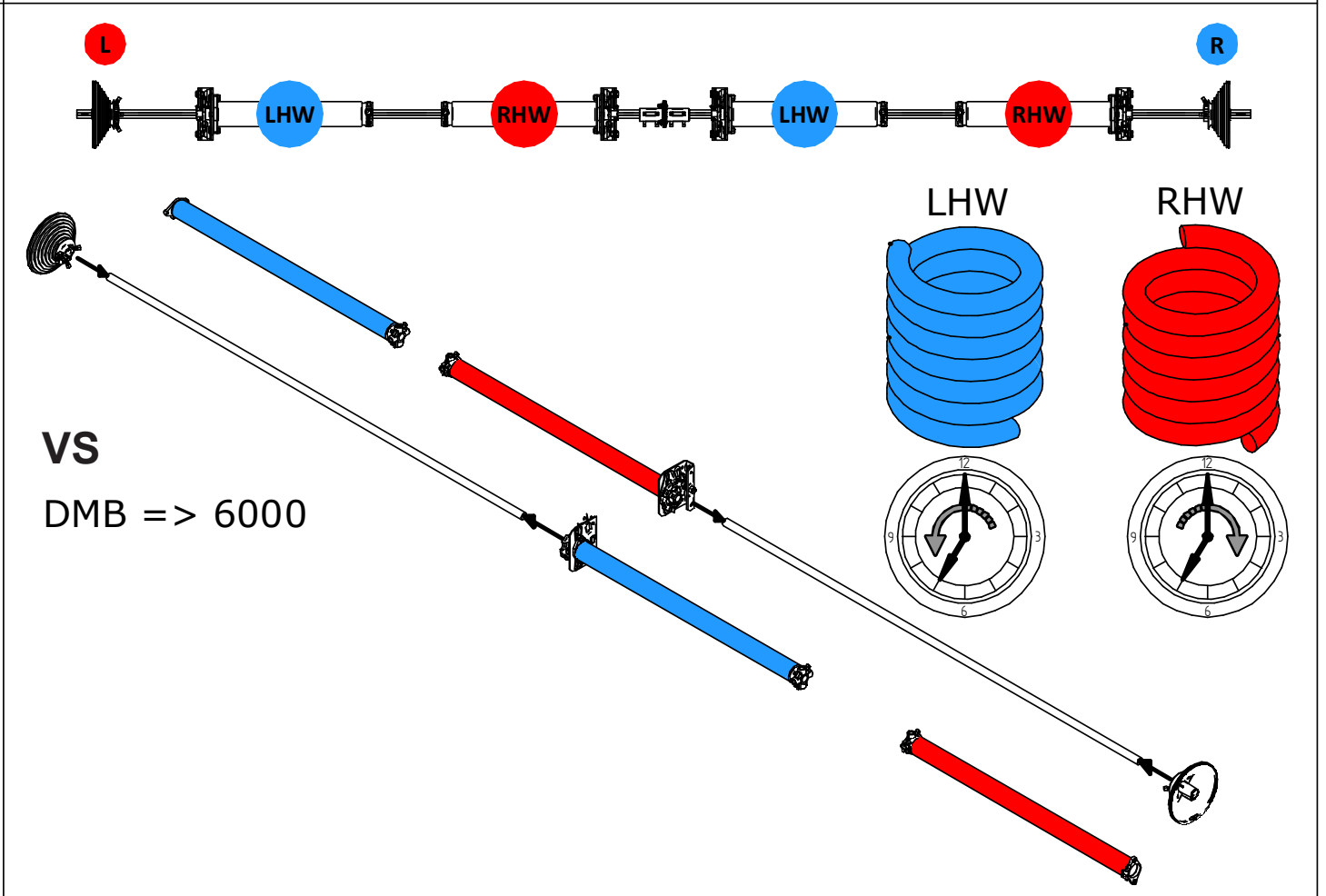

Attention! VS Spring configuration drawings on this page overrule all VS spring configuration drawings that follow in this assembly manual.

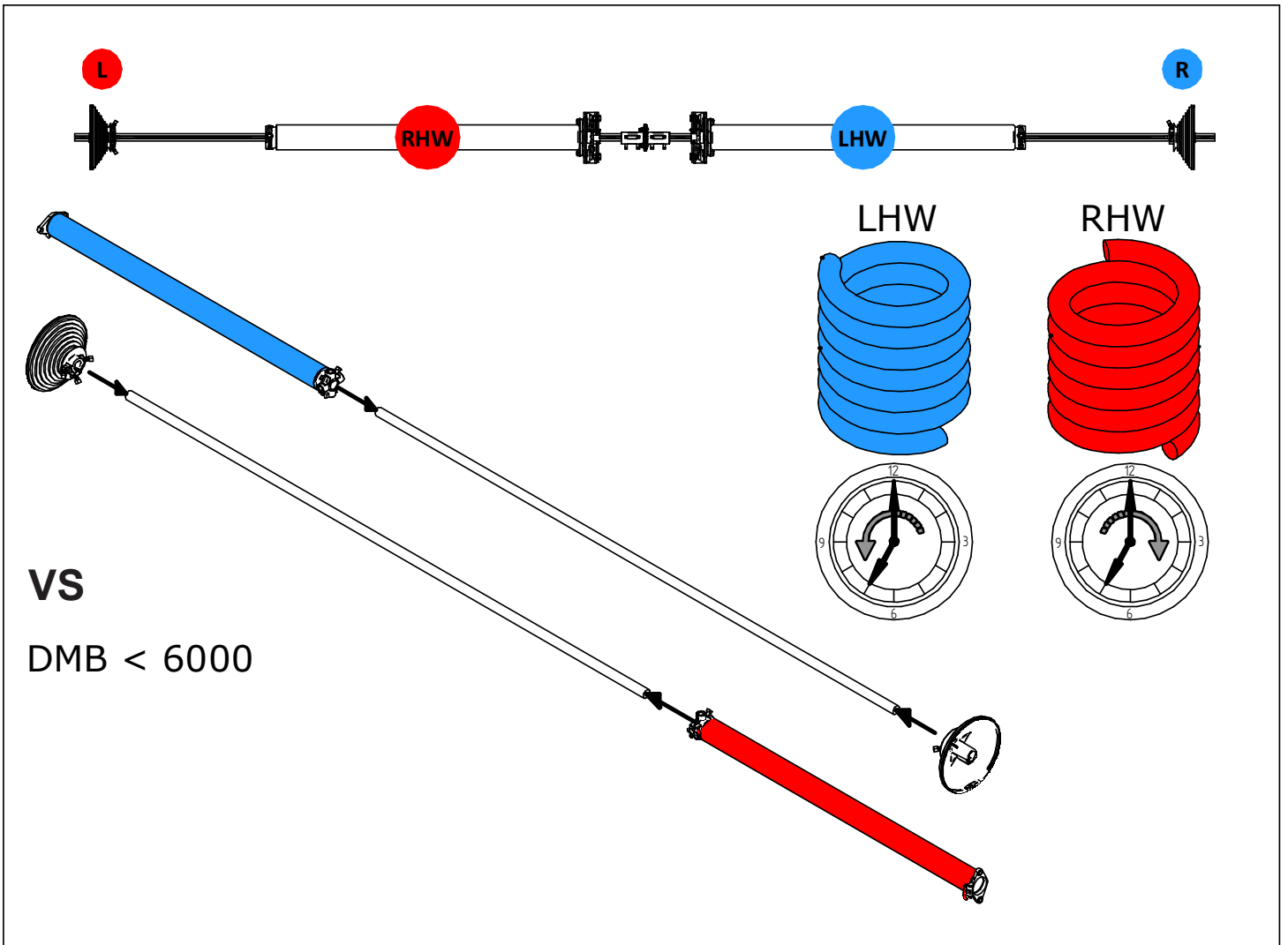

Attention! VSK Spring configuration drawings on this page overrule all VSK spring configuration drawings that follow in this assembly manual.

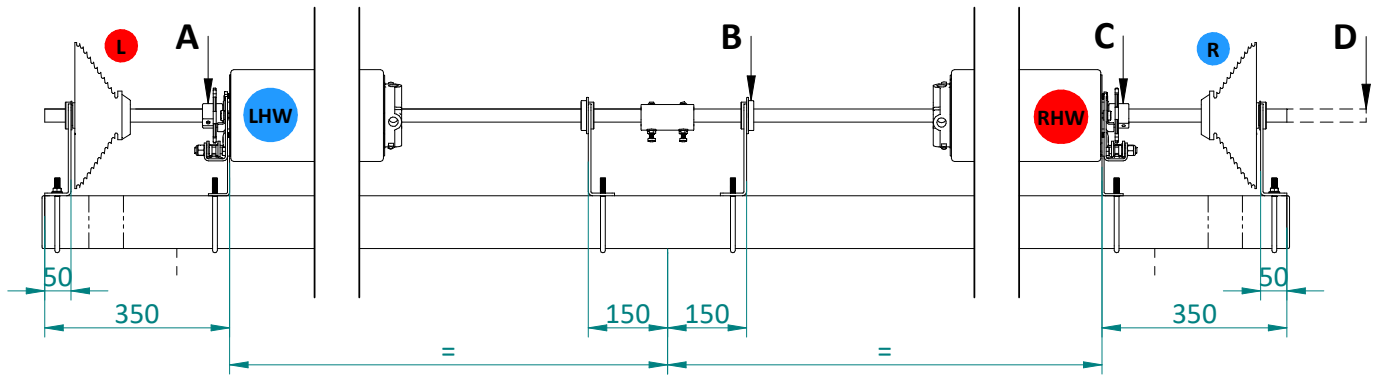

VSK
Standard & Direct

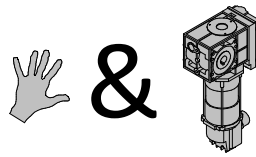

● = Blue
● = Red

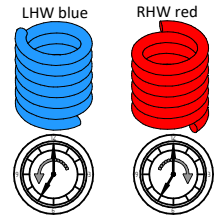

	A	B	C	D
NL	VBB LHW of Lagerplaat + lager	Als DMB > 4750mm	VBB RHW of Lagerplaat + lager	Motorbediend L of R
EN	SBD LHW or Bearing plate + bearing	When DLW > 4750mm	SBD RHW or Bearing plate + bearing	Motor operated L or R
DE	FBS LHW oder Lagerkonsole + lager	Wenn TLB > 4750mm	FBS RHW oder Lagerkonsole + lager	Antriebe L oder R
FR	Pare-chute ressort LHW ou palier + roulement	LDB > 4750mm	Pare-chute ressort RHW ou palier + roulement	Motorisée D ou G

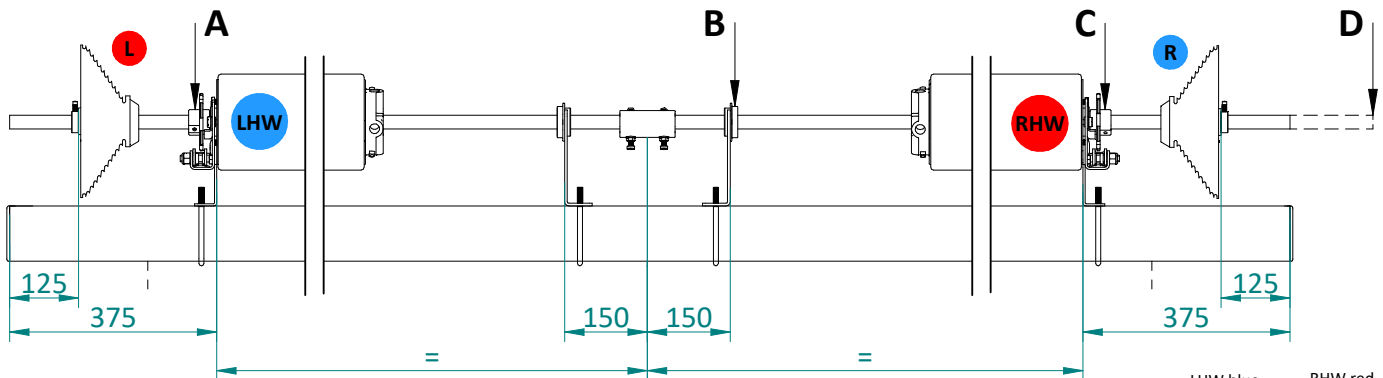

VSK
Top mounted

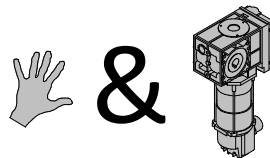

● = Blue
● = Red

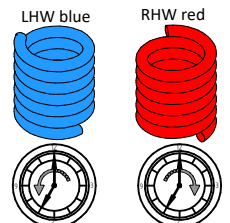

	A	B	C	D
NL	VBB LHW of Lagerplaat + lager + stelling	Als DMB > 4750mm	VBB RHW of Lagerplaat + lager + stelling	Motorbediend L of R
EN	SBD LHW or Bearing plate + bearing + shaft collar	When DLW > 4750mm	SBD RHW or Bearing plate + bearing + shaft collar	Motor operated L or R
DE	FBS LHW oder Lagerkonsole + lager + stelling	Wenn TLB > 4750mm	FBS RHW oder Lagerkonsole + lager + stelling	Antriebe L oder R
FR	Pare-chute ressort LHW ou palier + roulement + baque d'arrêt	LDB > 4750mm	Pare-chute ressort RHW ou palier + roulement + baque d'arrêt	Motorisée D ou G

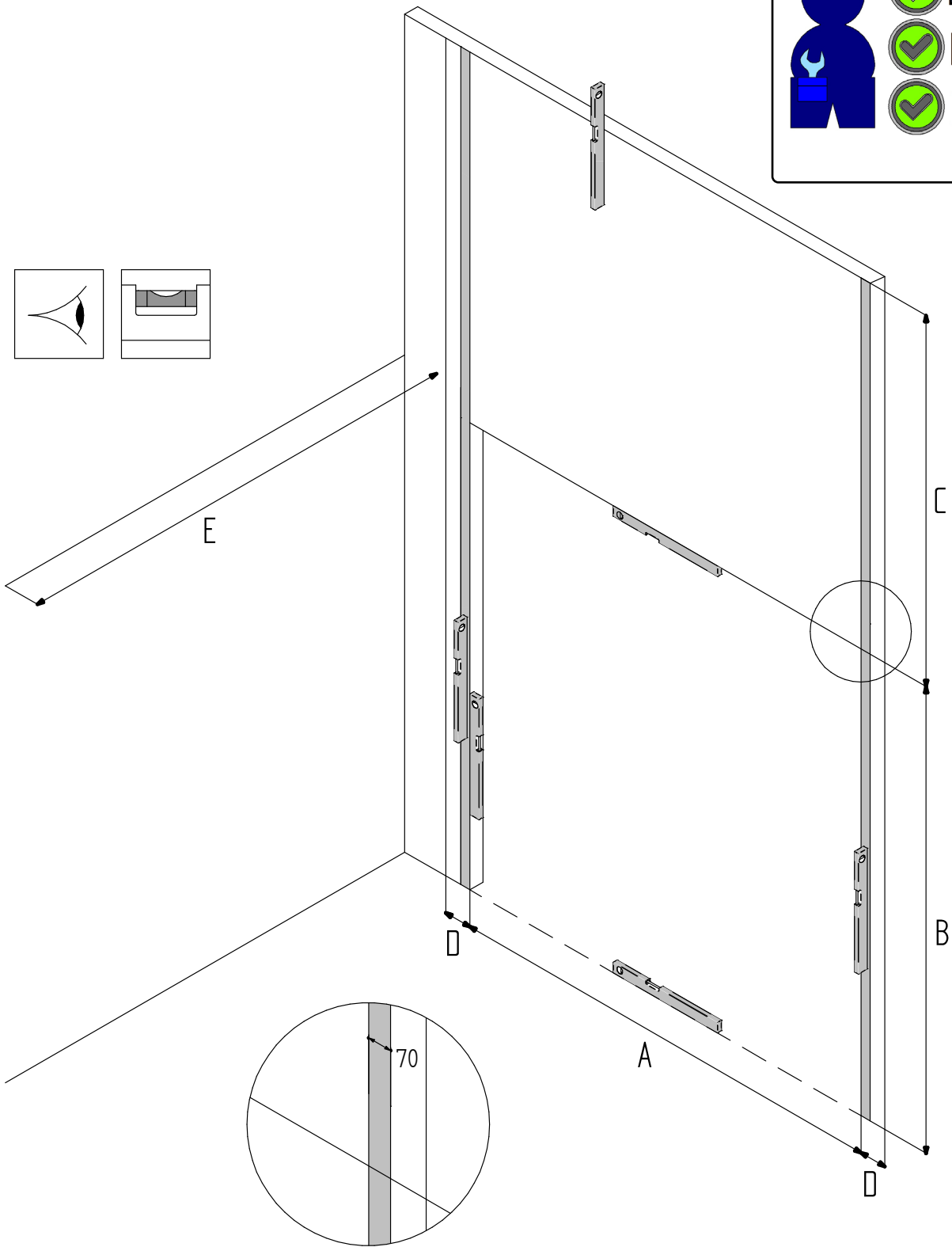
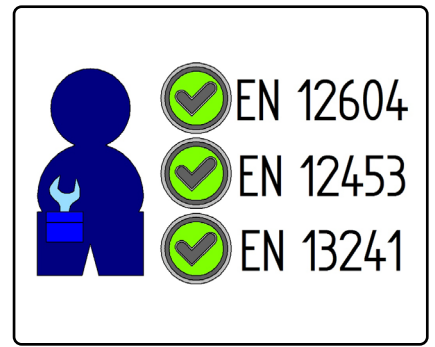

	A	B	C	D	E
	DLW	DLH	FHR	FSR	FMD
NL	Dagmaat breedte	Dagmaat hoogte	Vrije bovenruimte	Vrije zijruimte	Inbouwdiepte
EN	Day Light Width	Day Light Height	Free Head Room	Free Side Room	Free Mounting Depth
DE	Tageslichtbreite	Tageslichtehöhe	Sturzfreiraum	Freie Seitenraum	Freie Einbautiefe
FR	Largeur de baie	Hauteur de baie	Linteau disponible	Ecoinçons Requis	Recul
RO	Lățime Gol	Înălțime Gol	Buiandrug Liber	Spațiul Liber Lateral	Spațiul Liber în Adâncime
HU	Szélesség	Magasság	Szabad szemöldök magasság	Szabad hely oldalt	Szabad beépítési mélység
SE	Dager bredd	Dager höjd	Minsta erforderligt höjdutrymme	Fritt sidoutrymme	Fritt monterings utrymme

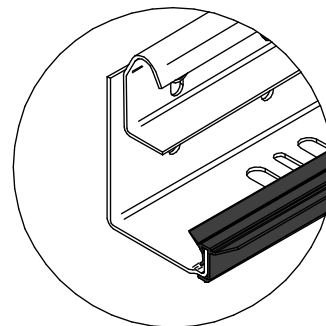
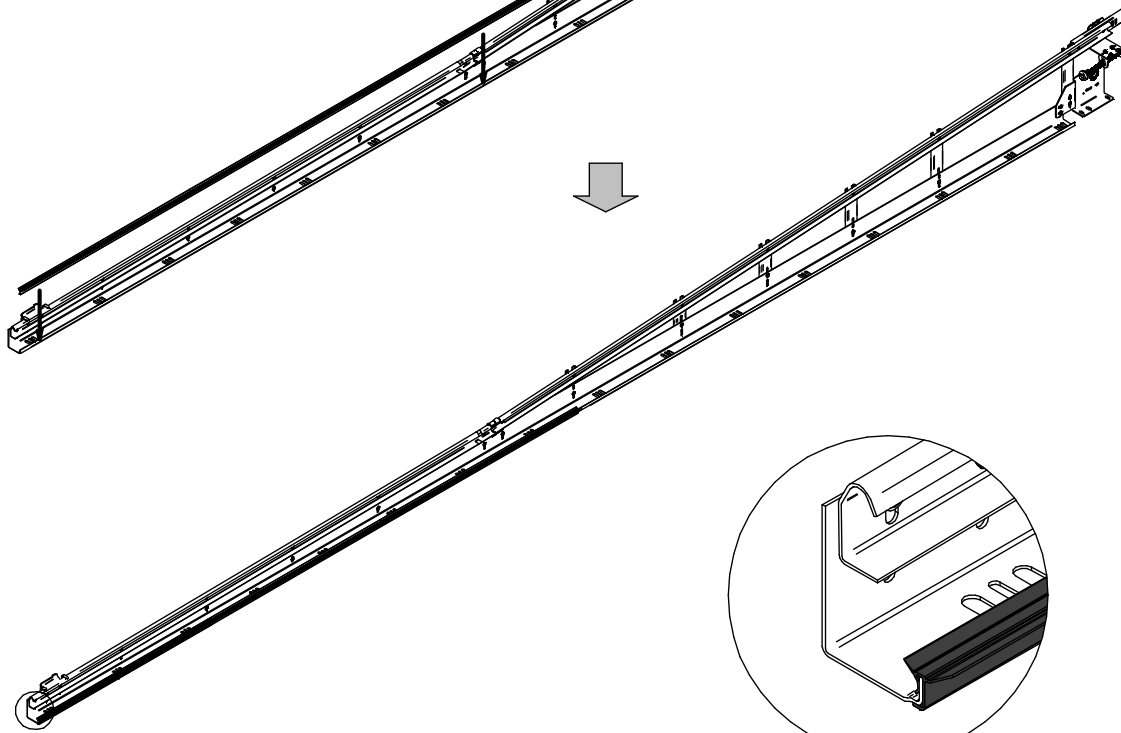
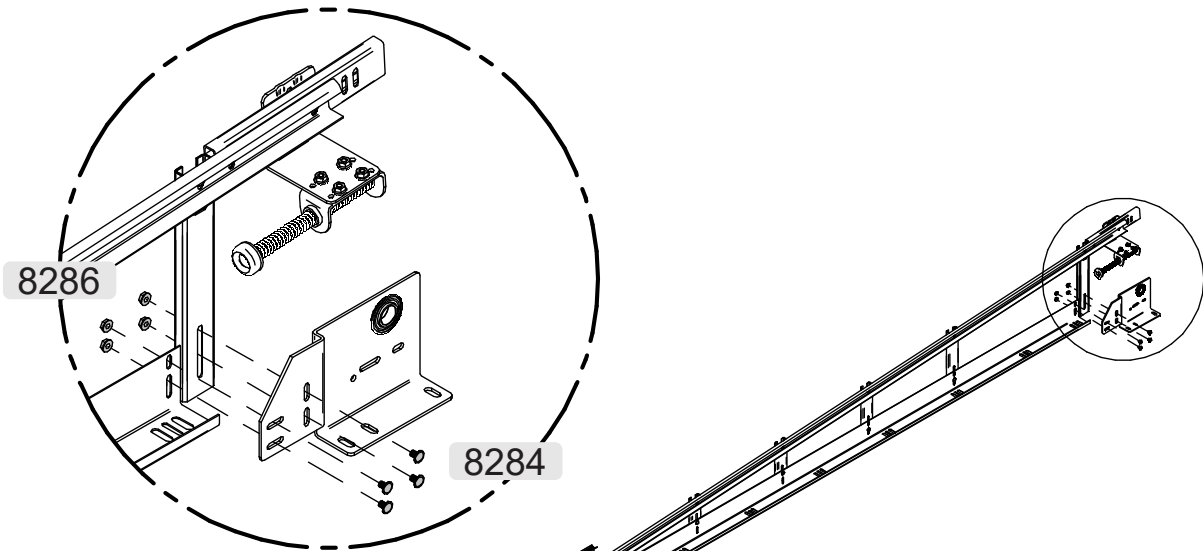
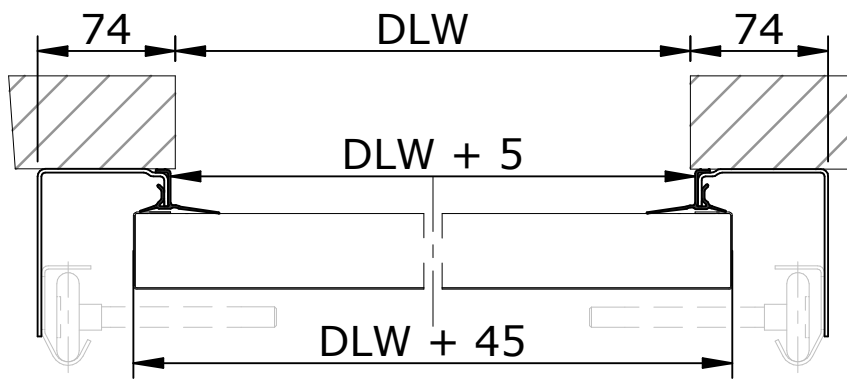

3199

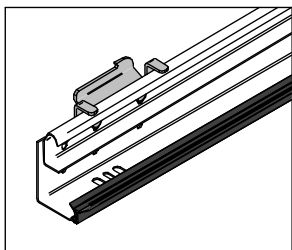

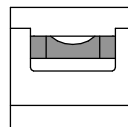
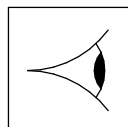
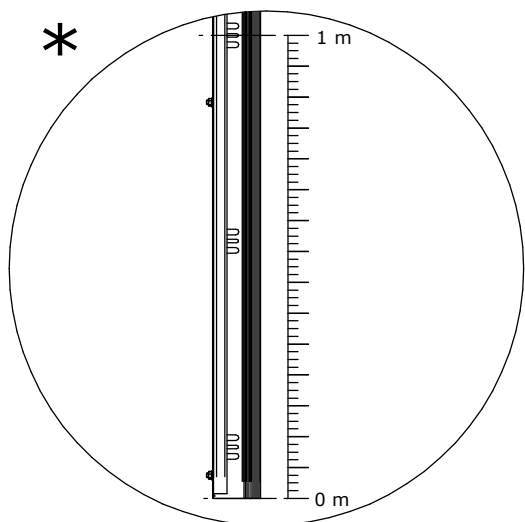
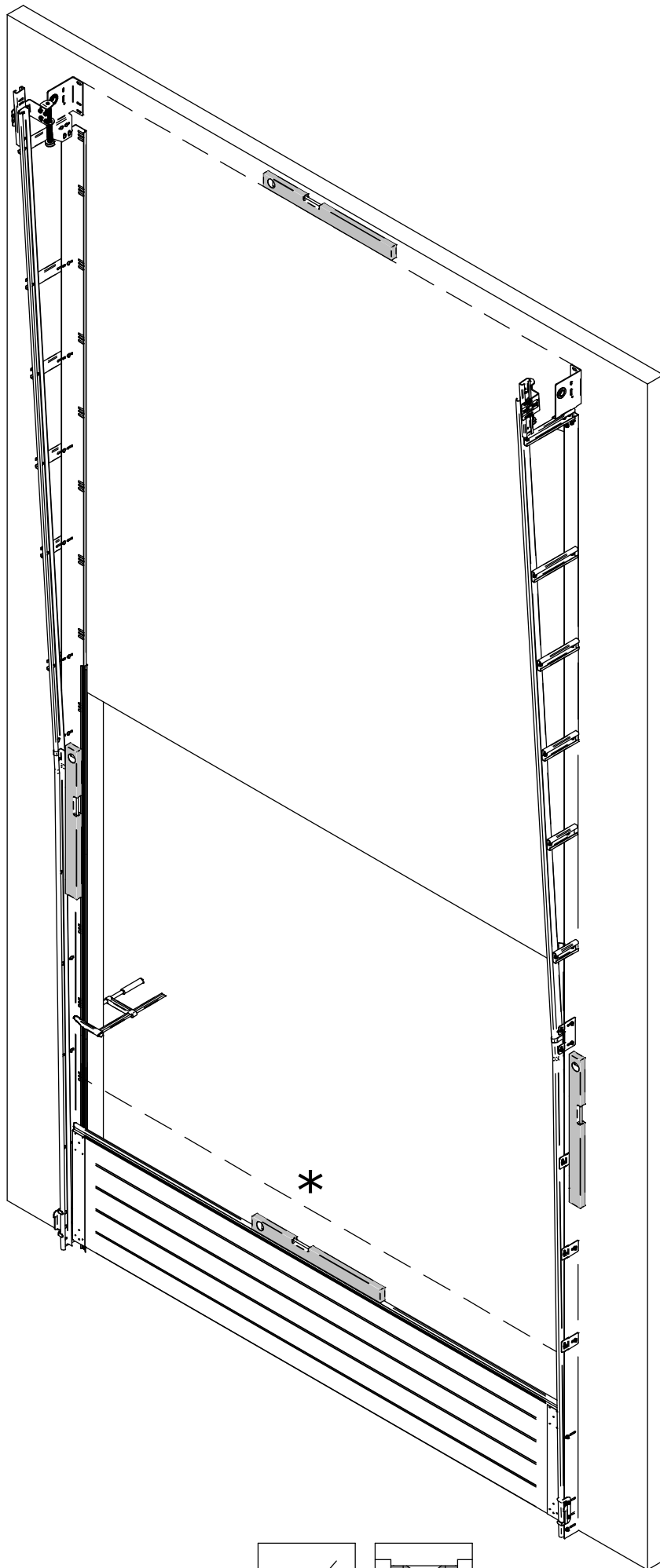

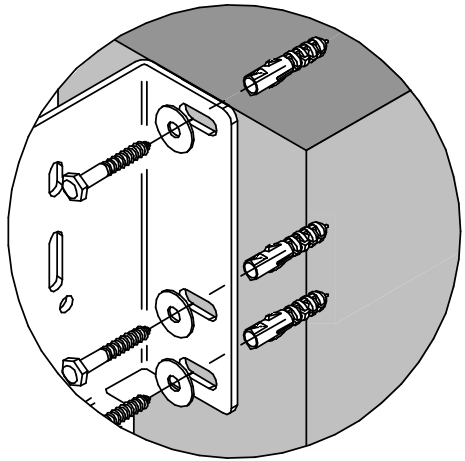
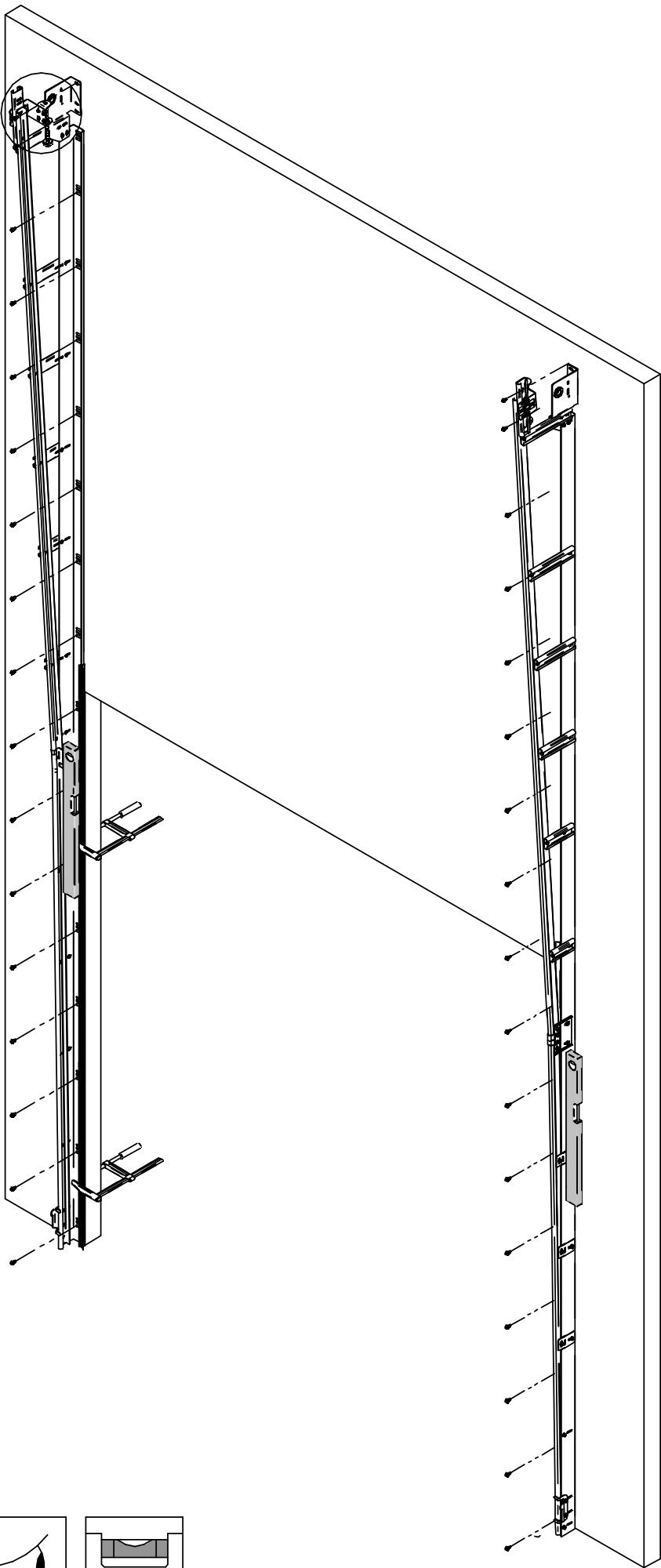

φ10

0351

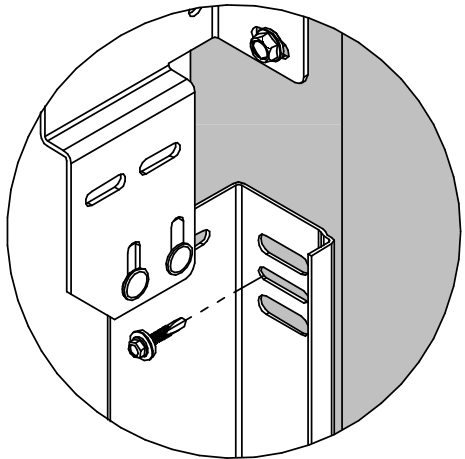

φ6

8011

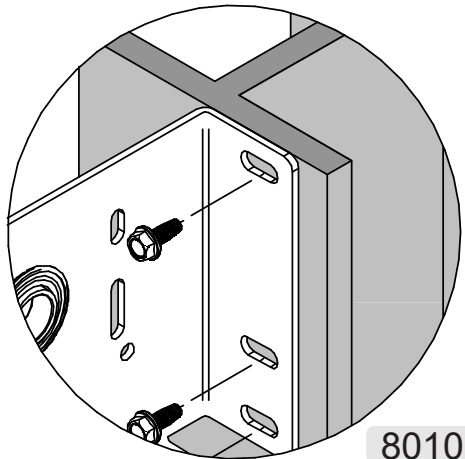

φ8

8010

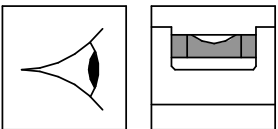

VS

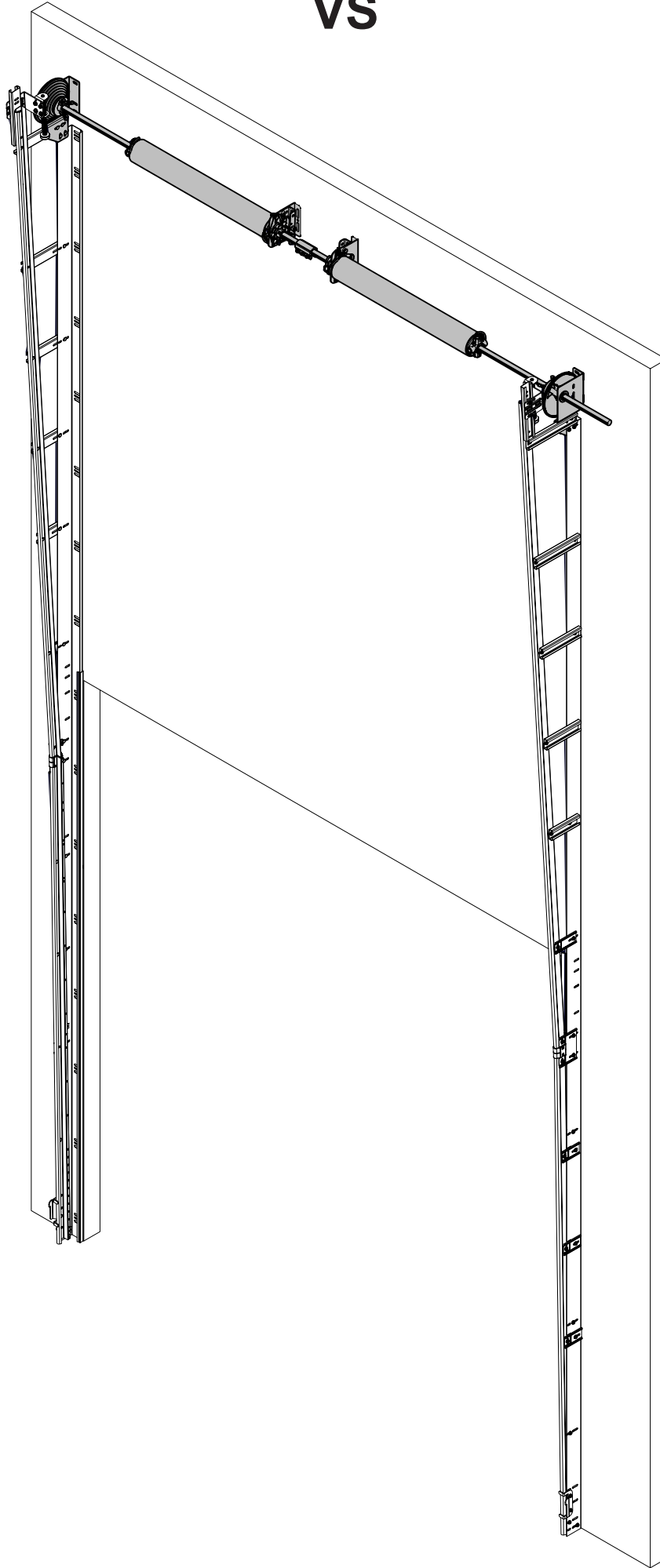

VSK Standaard / Standard / Au linteau

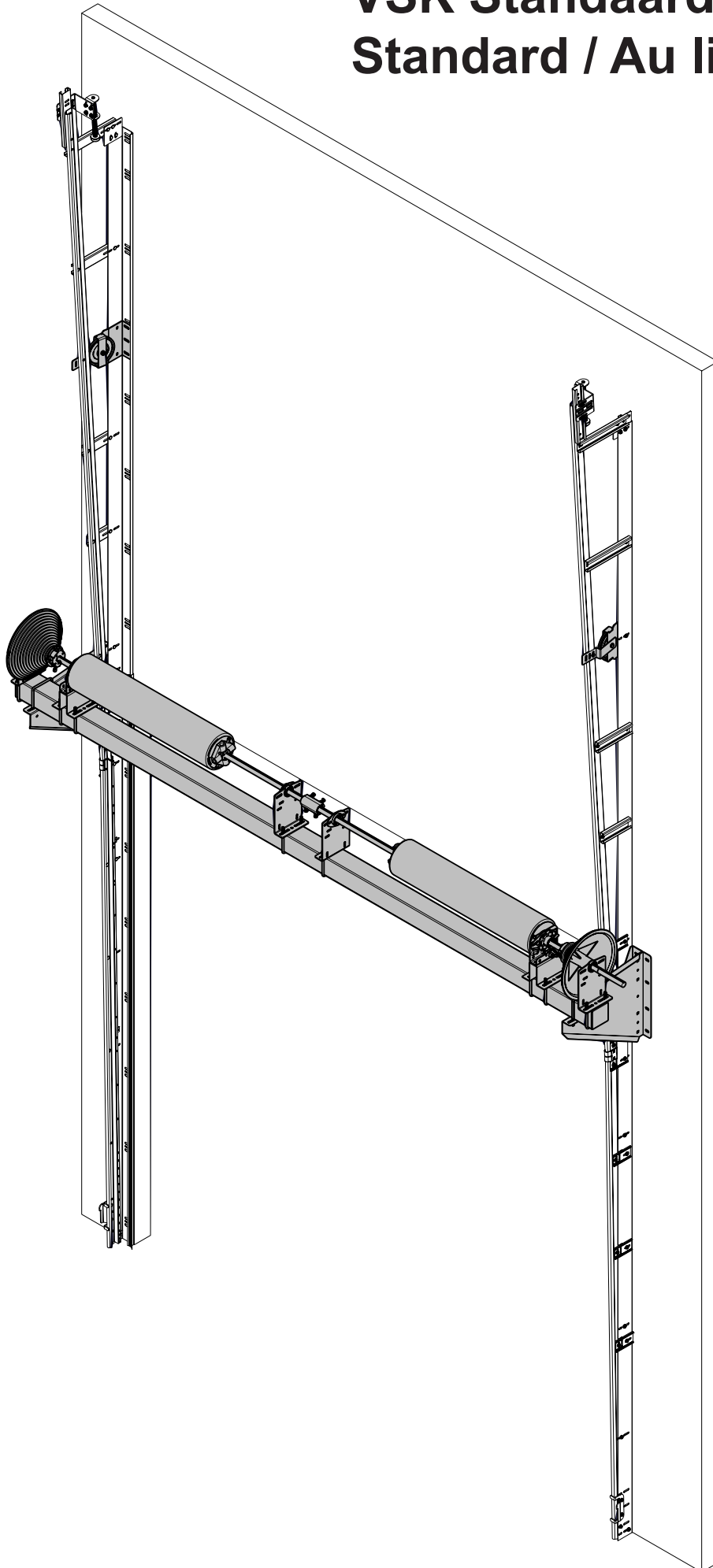

VSK SBD position

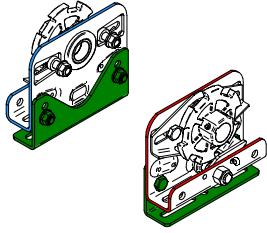
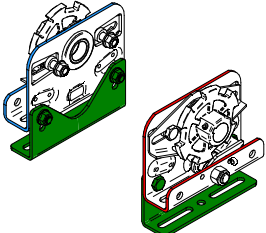
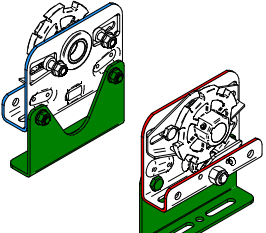
<p>2 Springs + 4 Springs outer springs</p>			
	111 - 3164	127 - 3164	152 - 3165

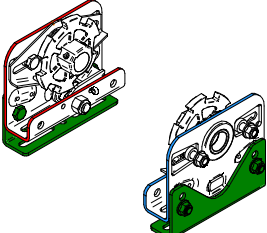
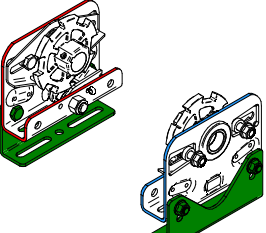
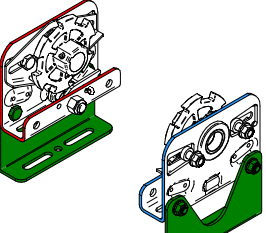
<p>4 Springs inner springs</p>			
	111 - 3164	127 - 3164	152 - 3165

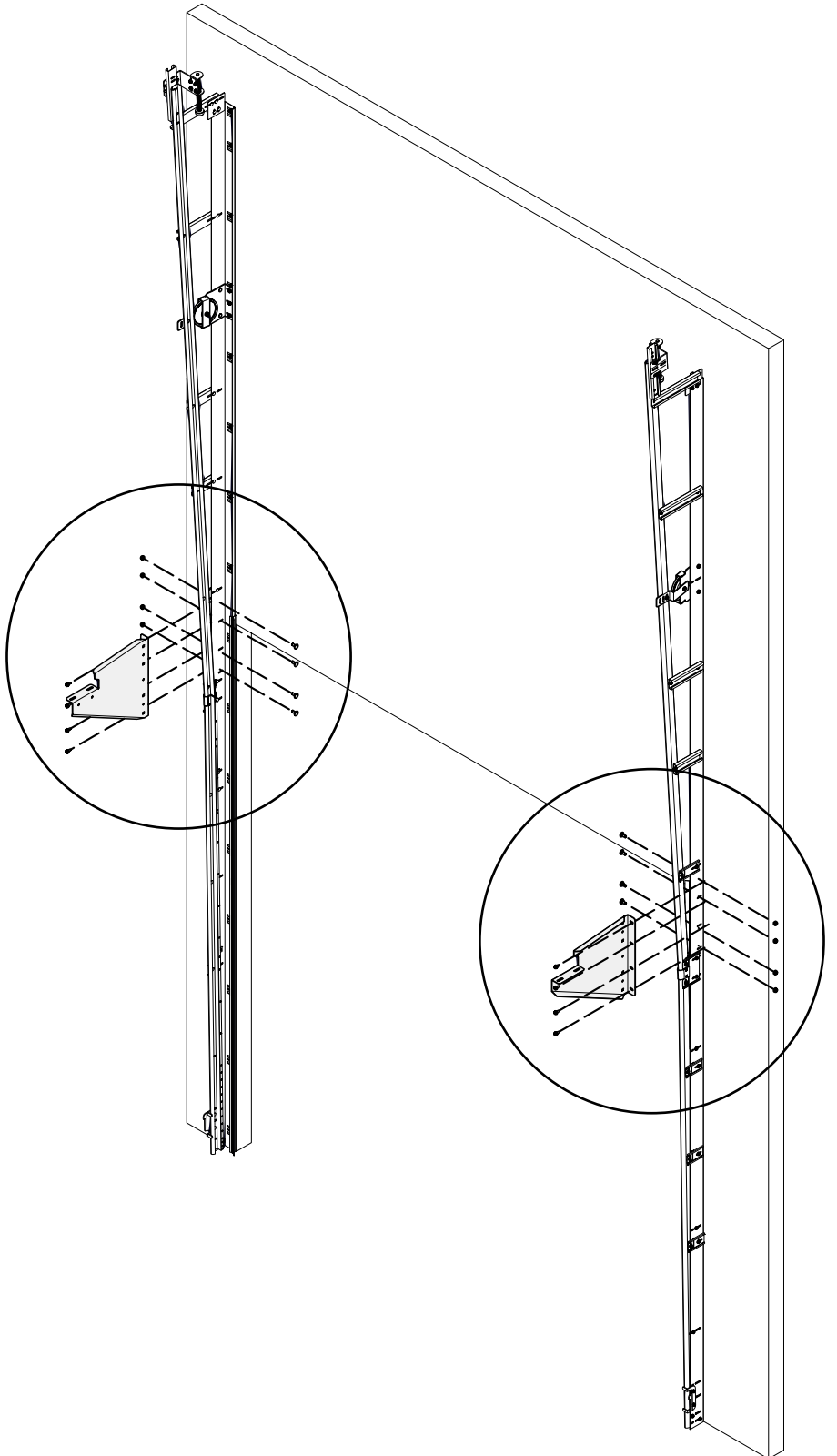
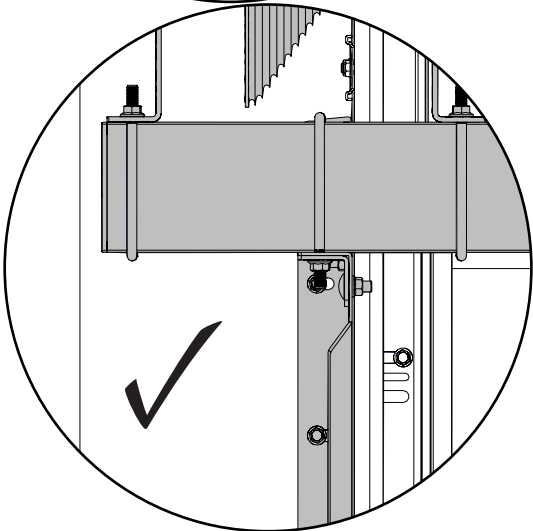
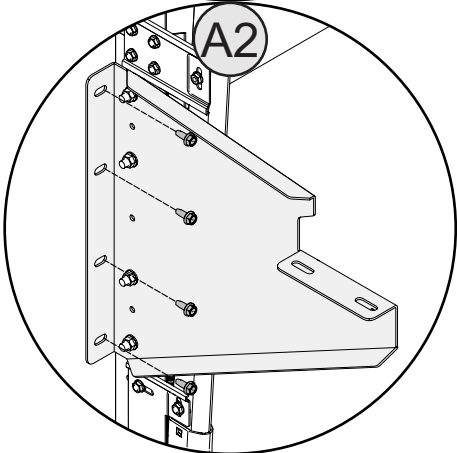
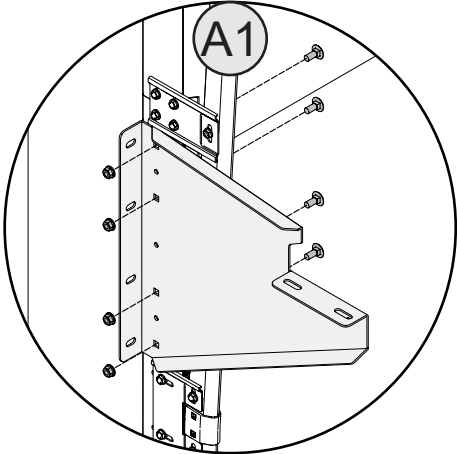
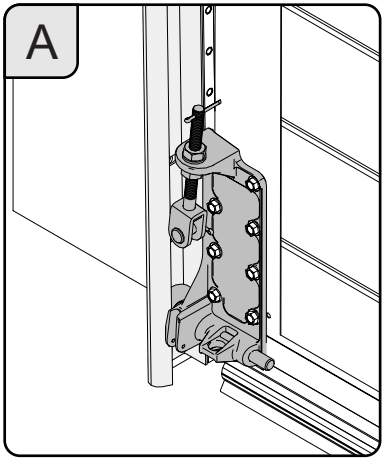

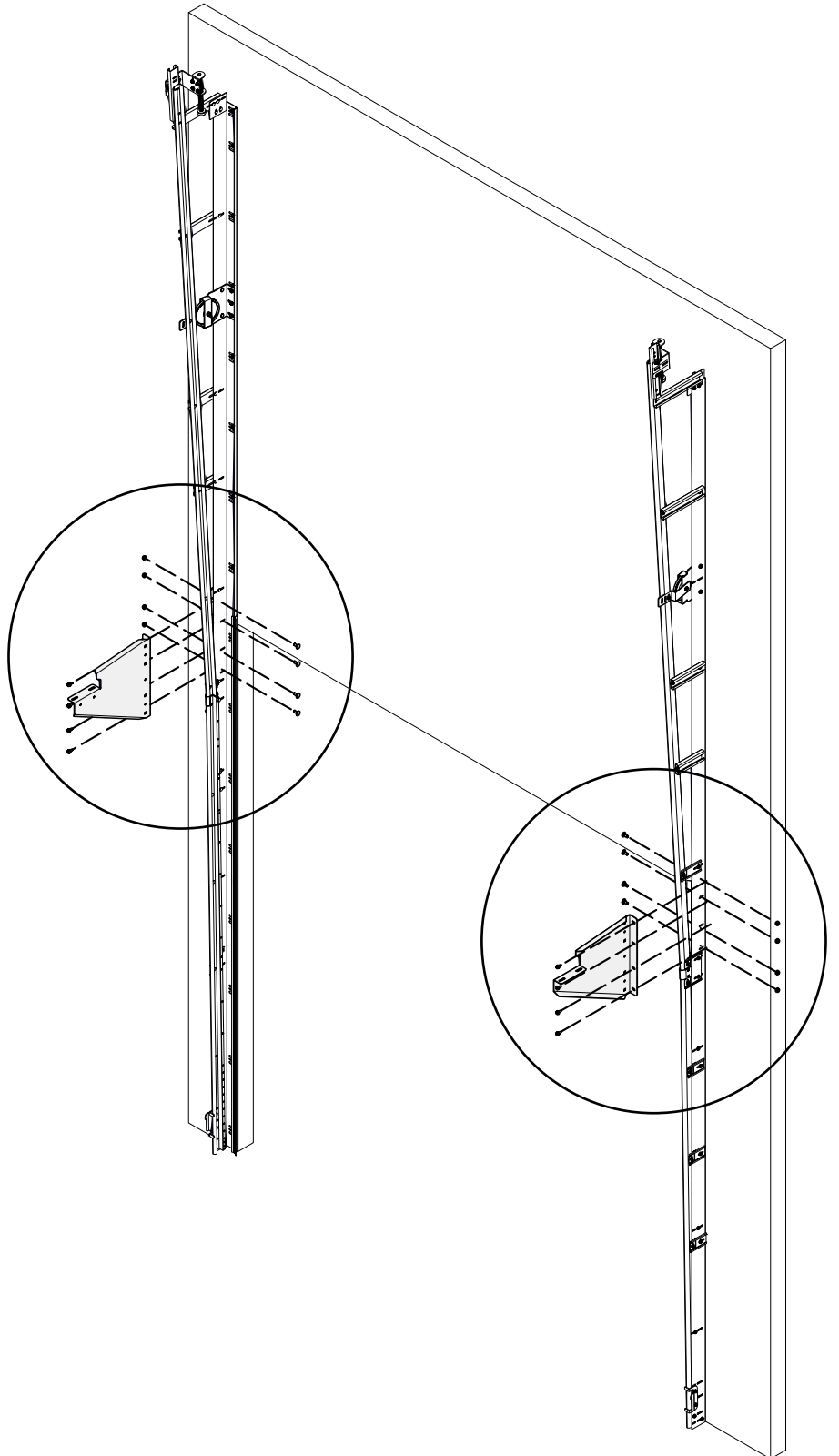
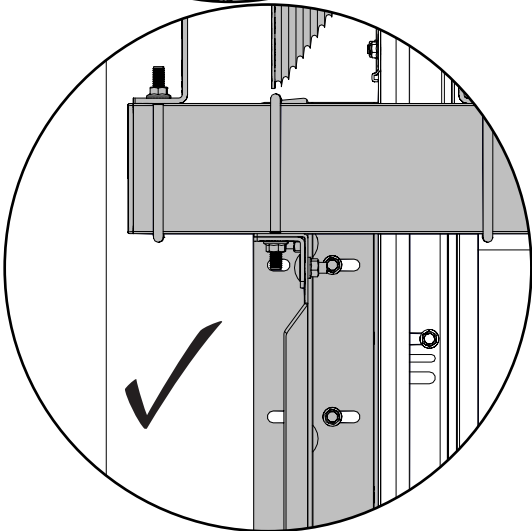
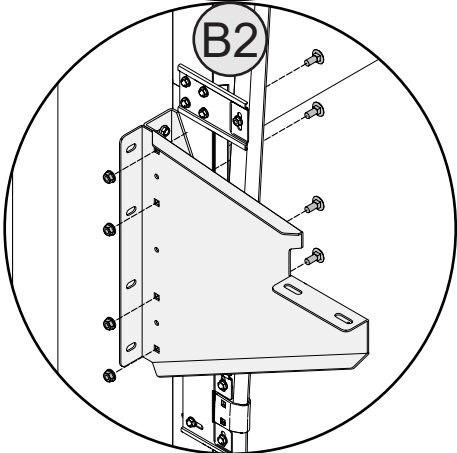
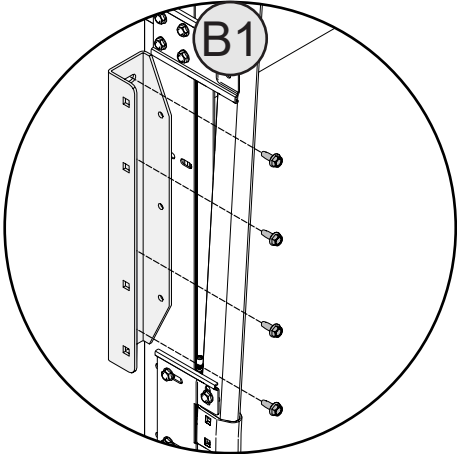
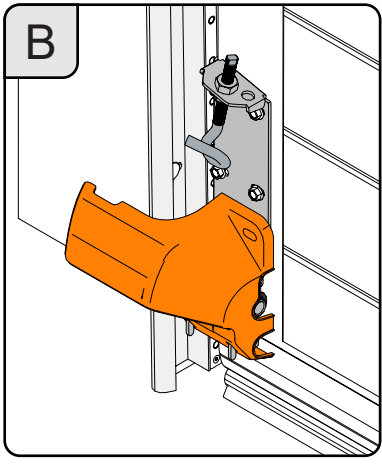

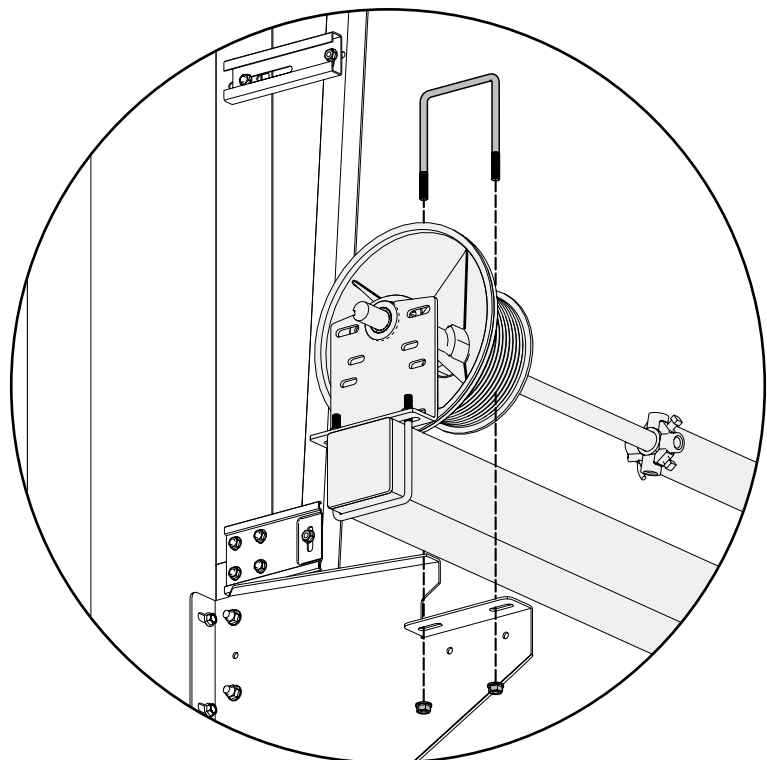
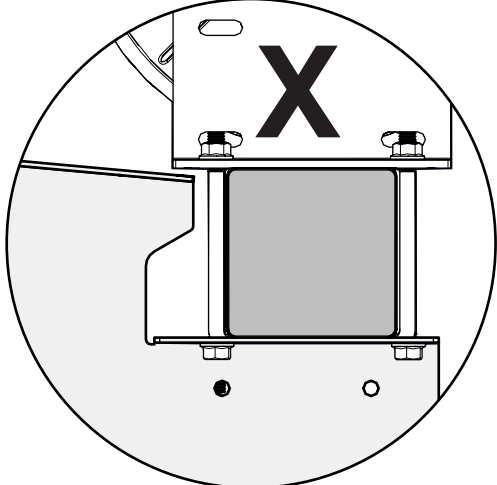
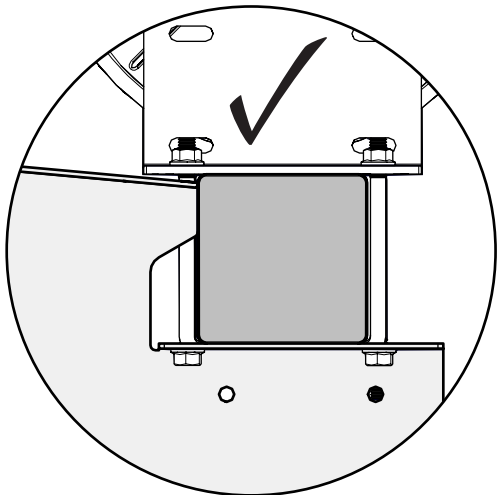
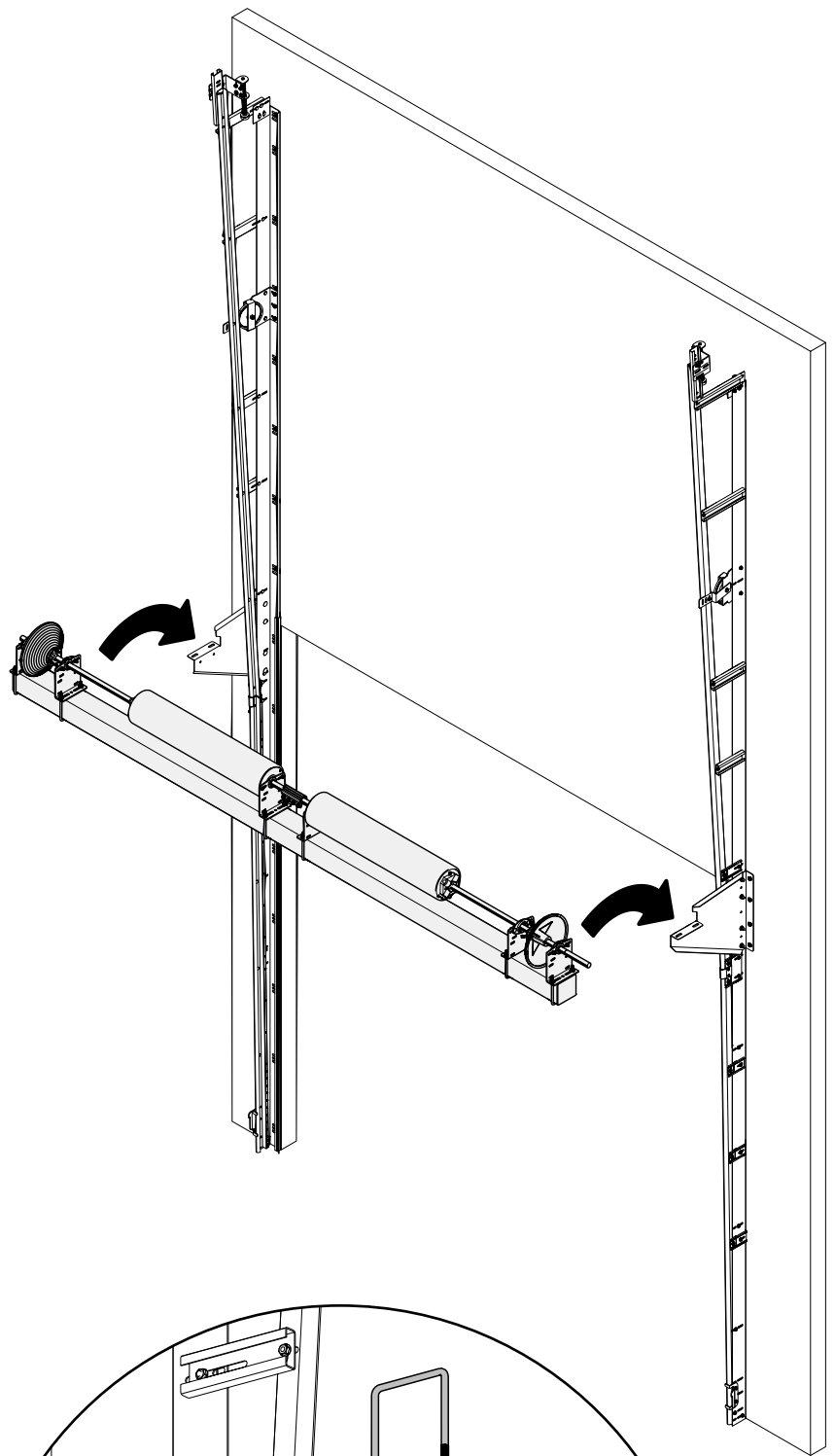

VSK Top

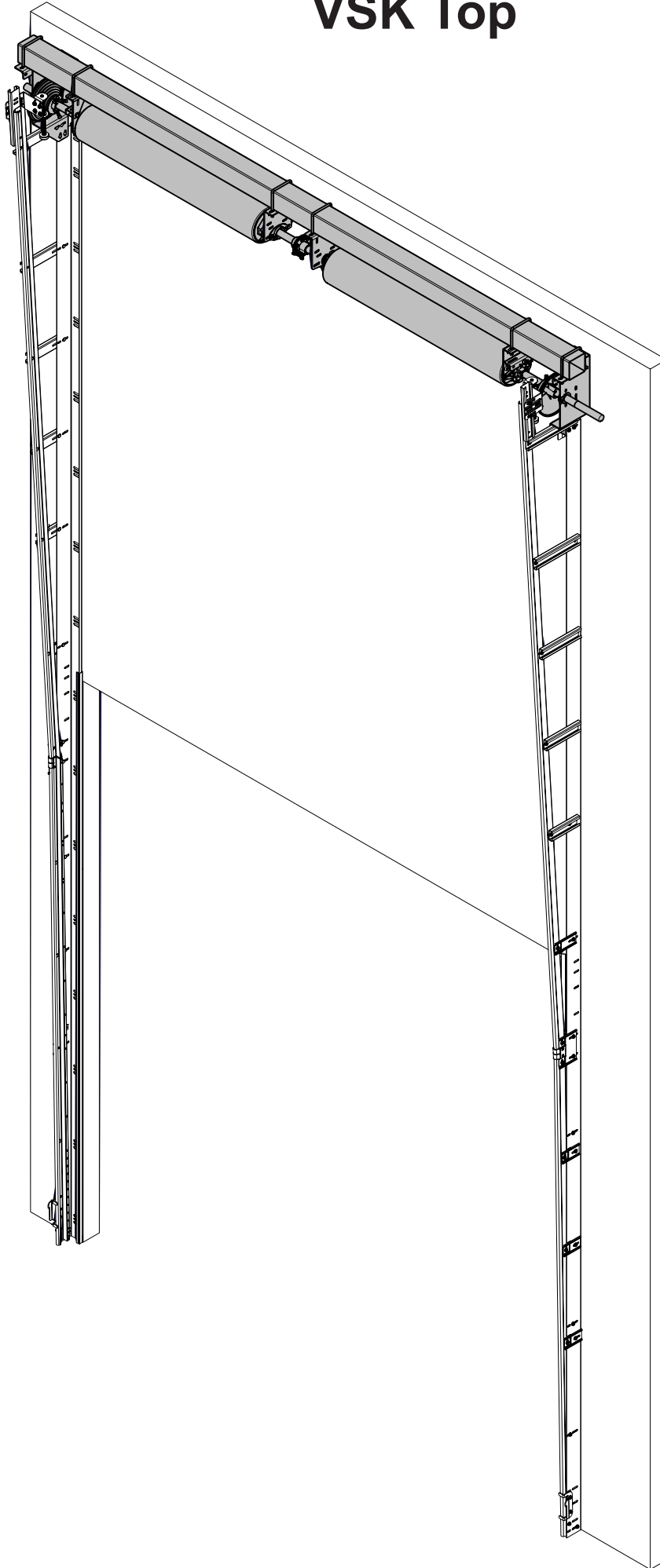

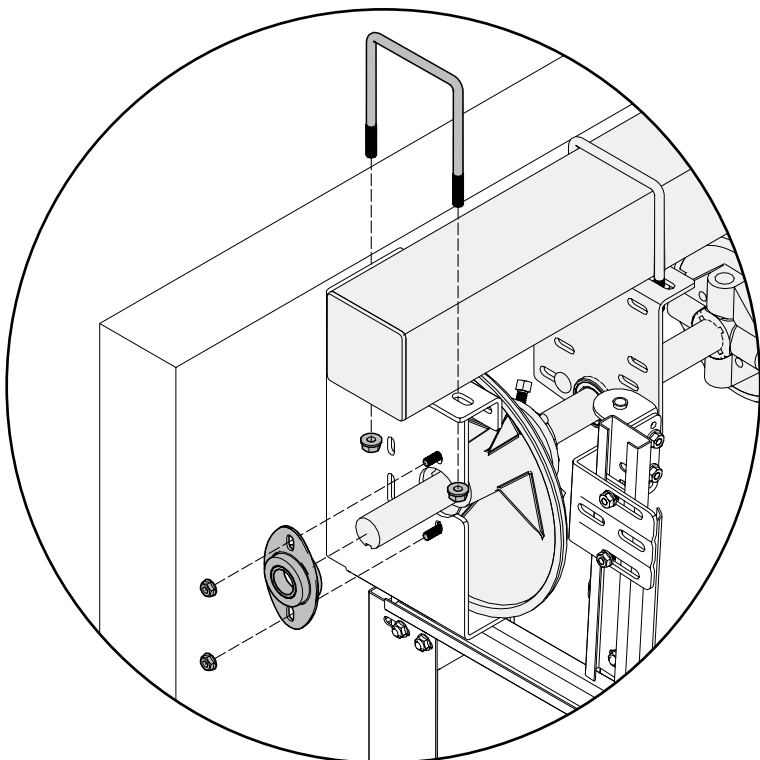
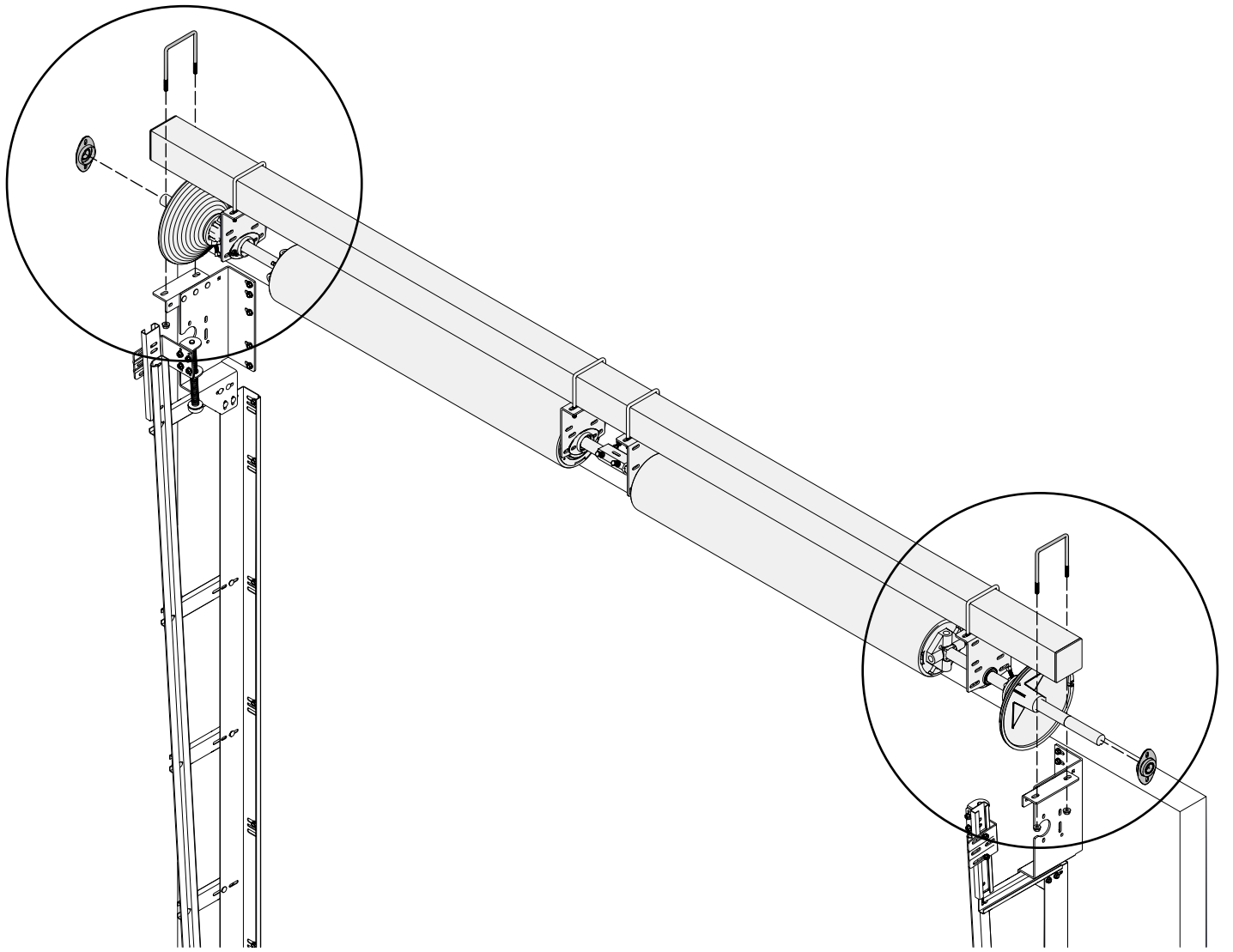

VSK Cables outside

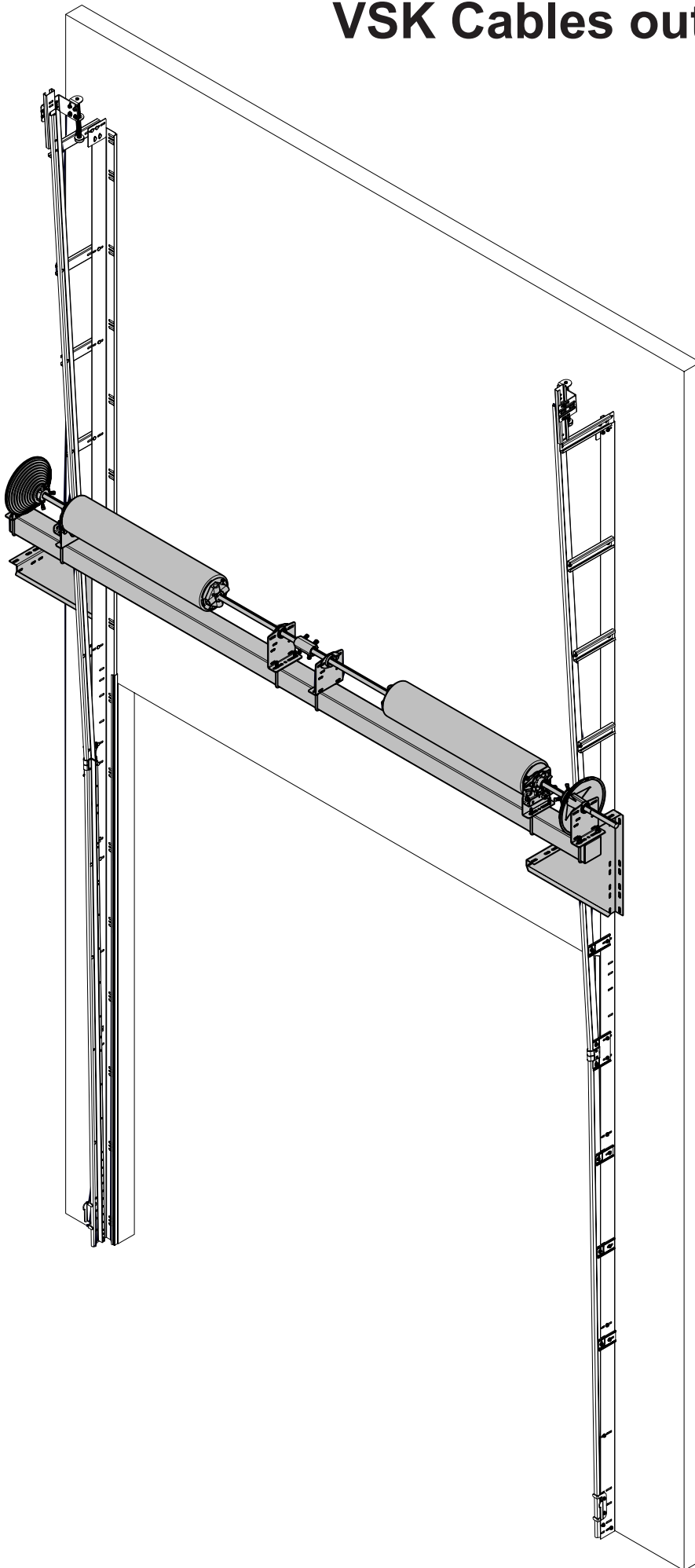

VSK Buitenom / Aussen / Outside / Au linteau câble à l'ext

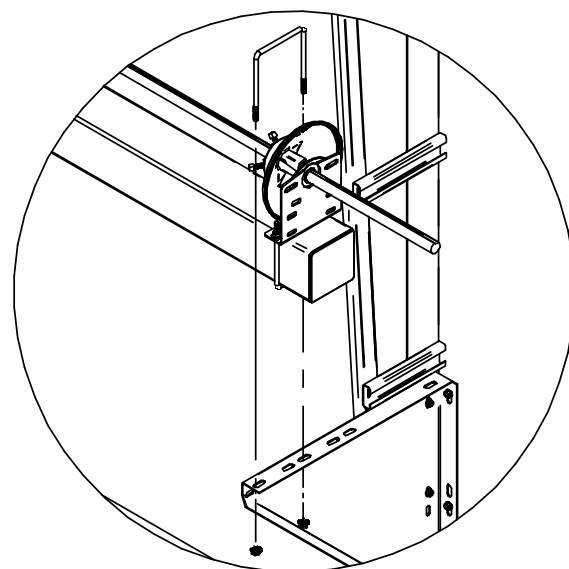
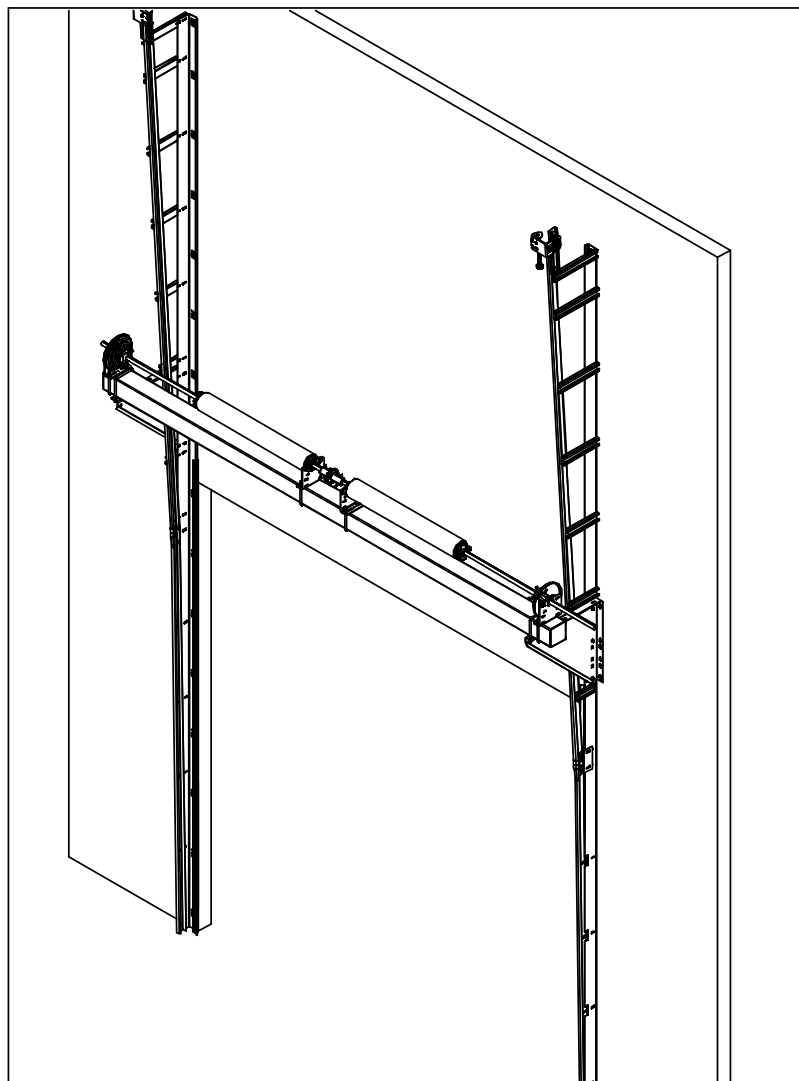
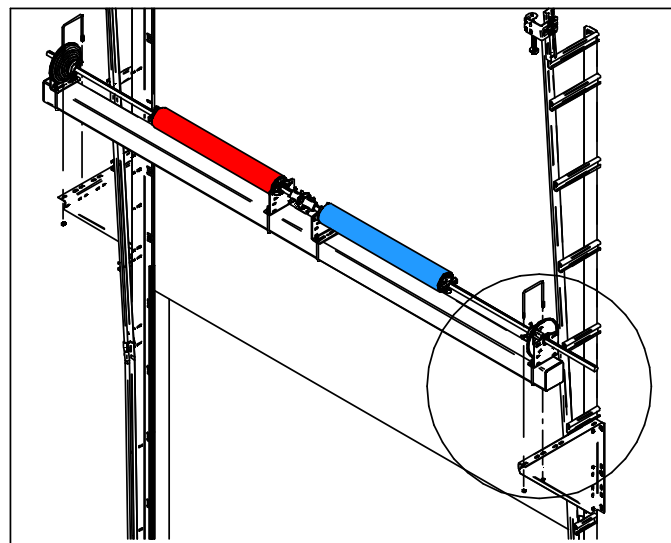
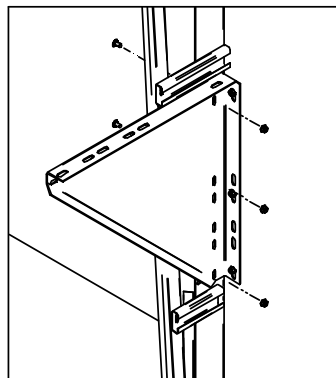
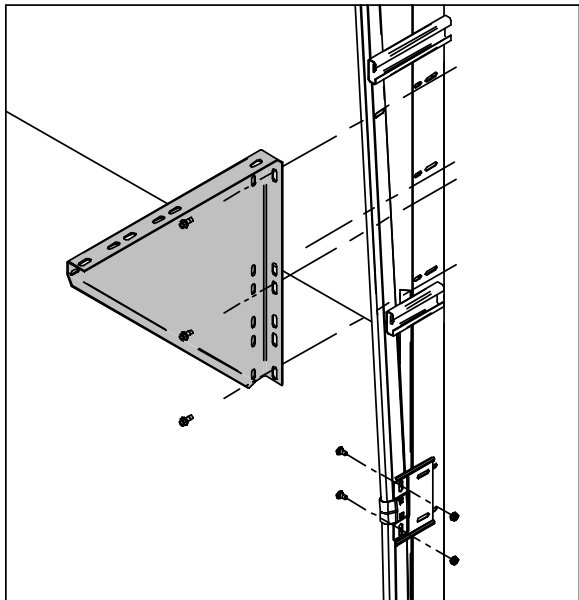

LHW

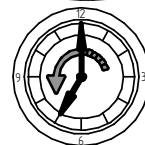
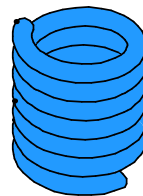

RHW

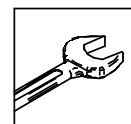
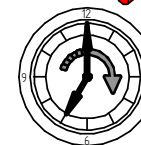
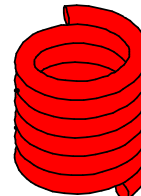

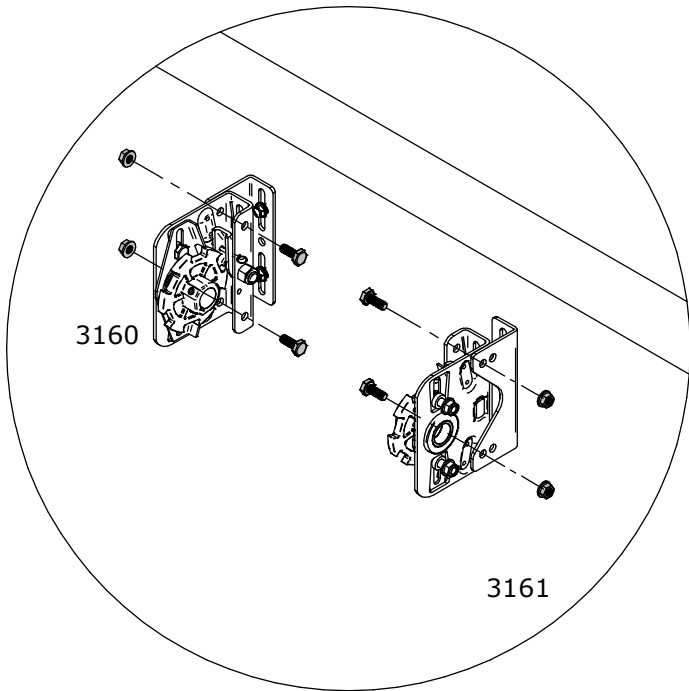
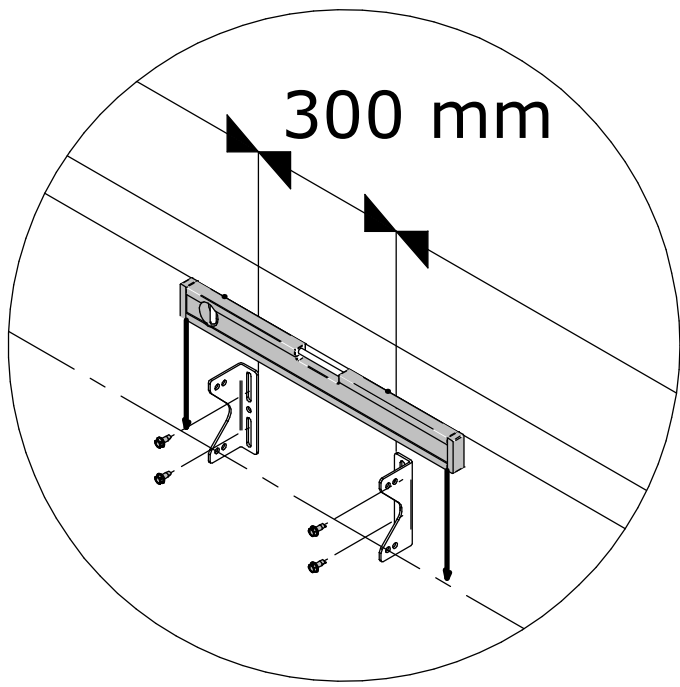

3160

3161

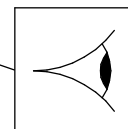
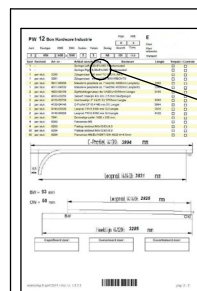
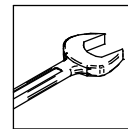
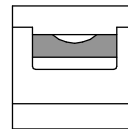
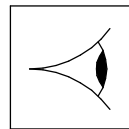
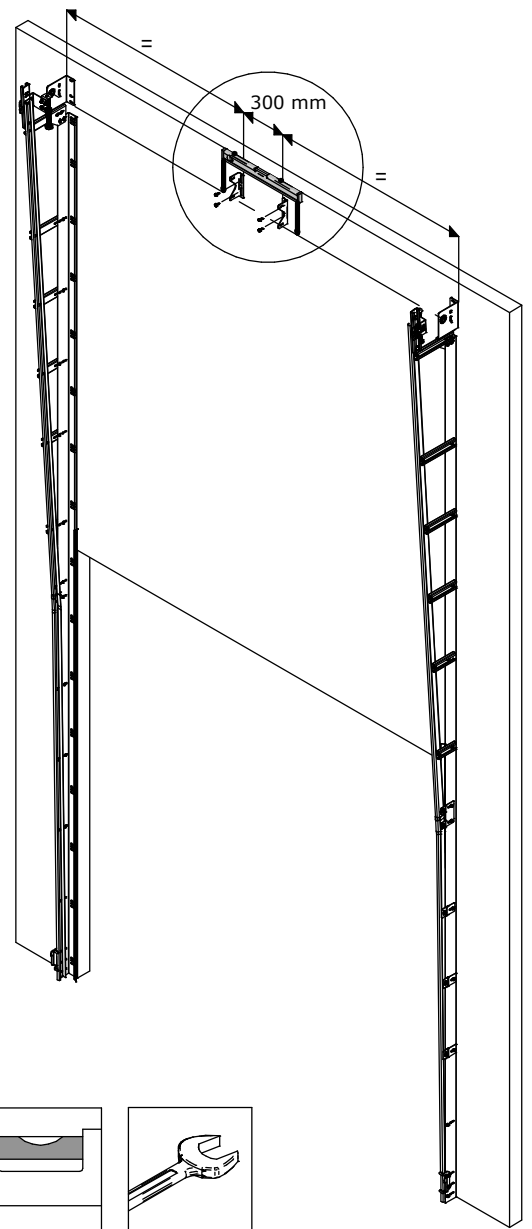
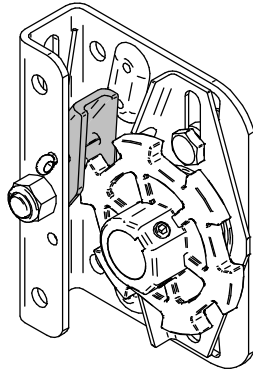
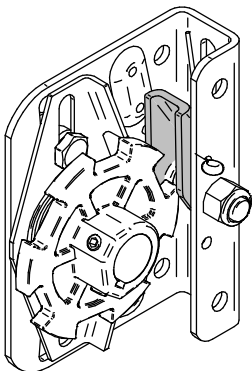

67 mm
95 mm

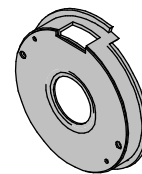

152 mm

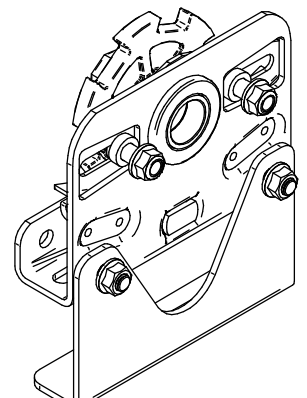
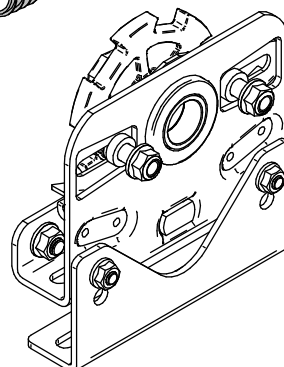

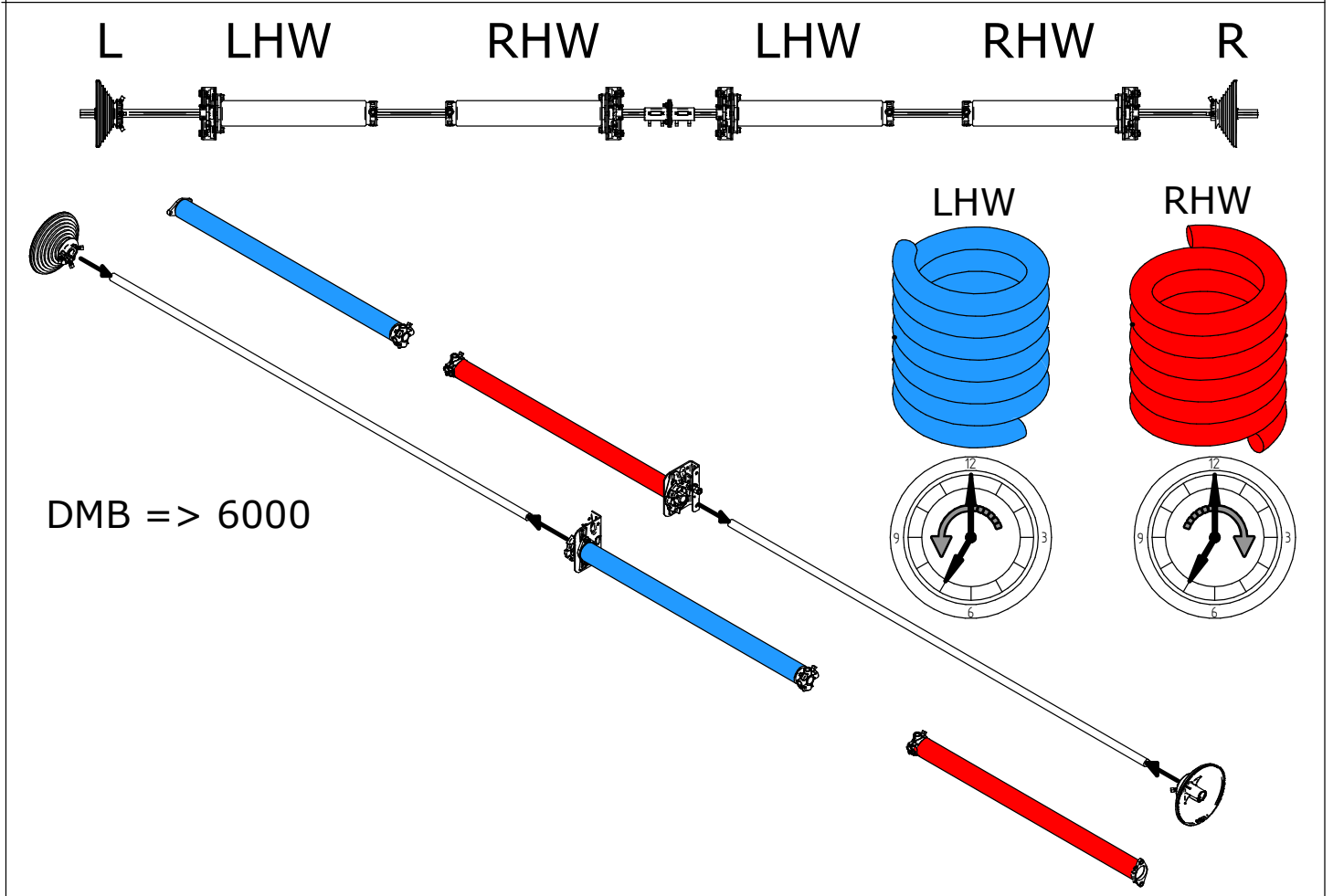
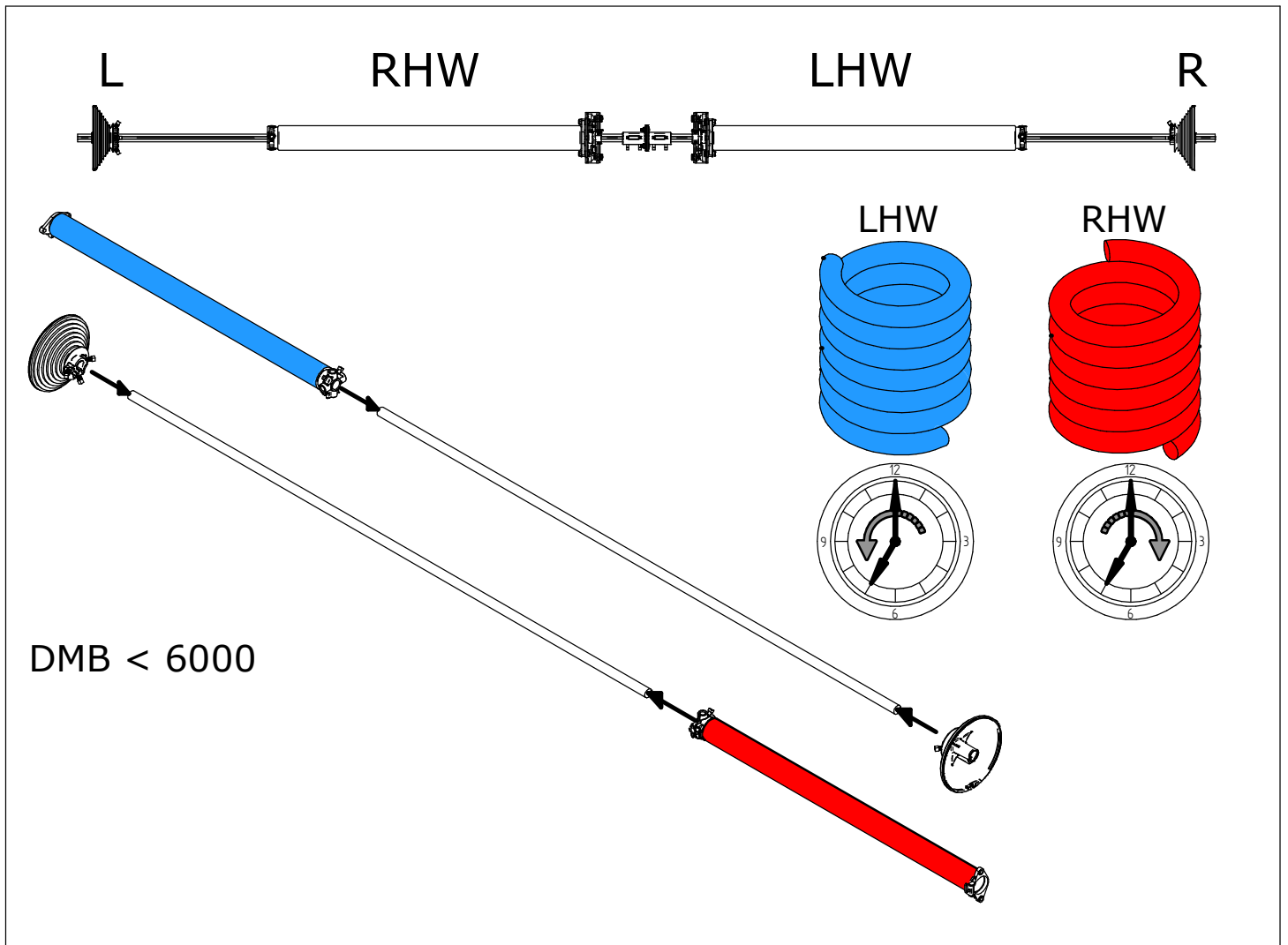

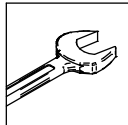
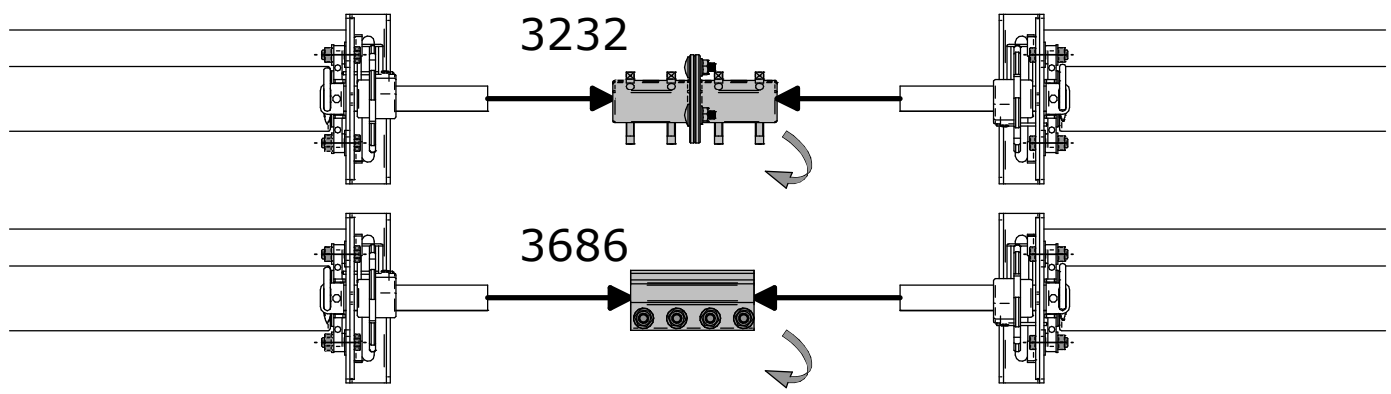
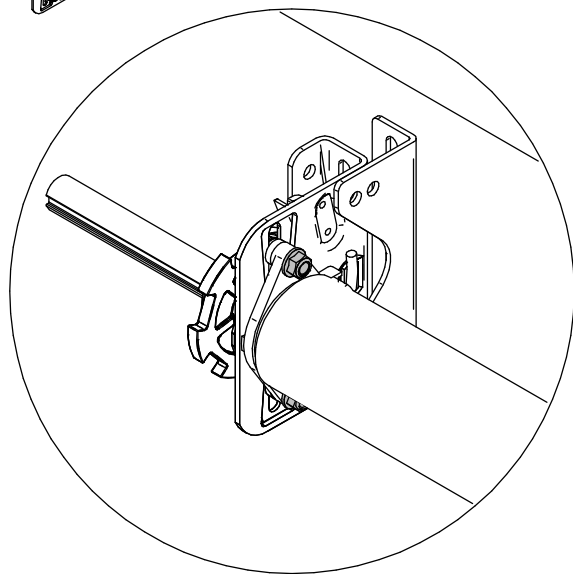
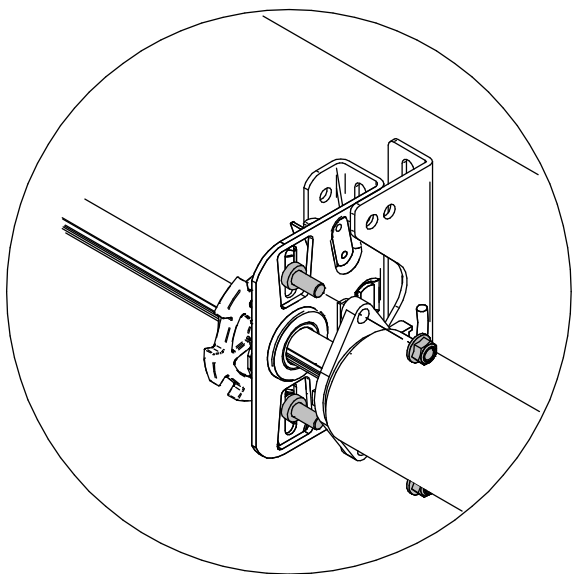
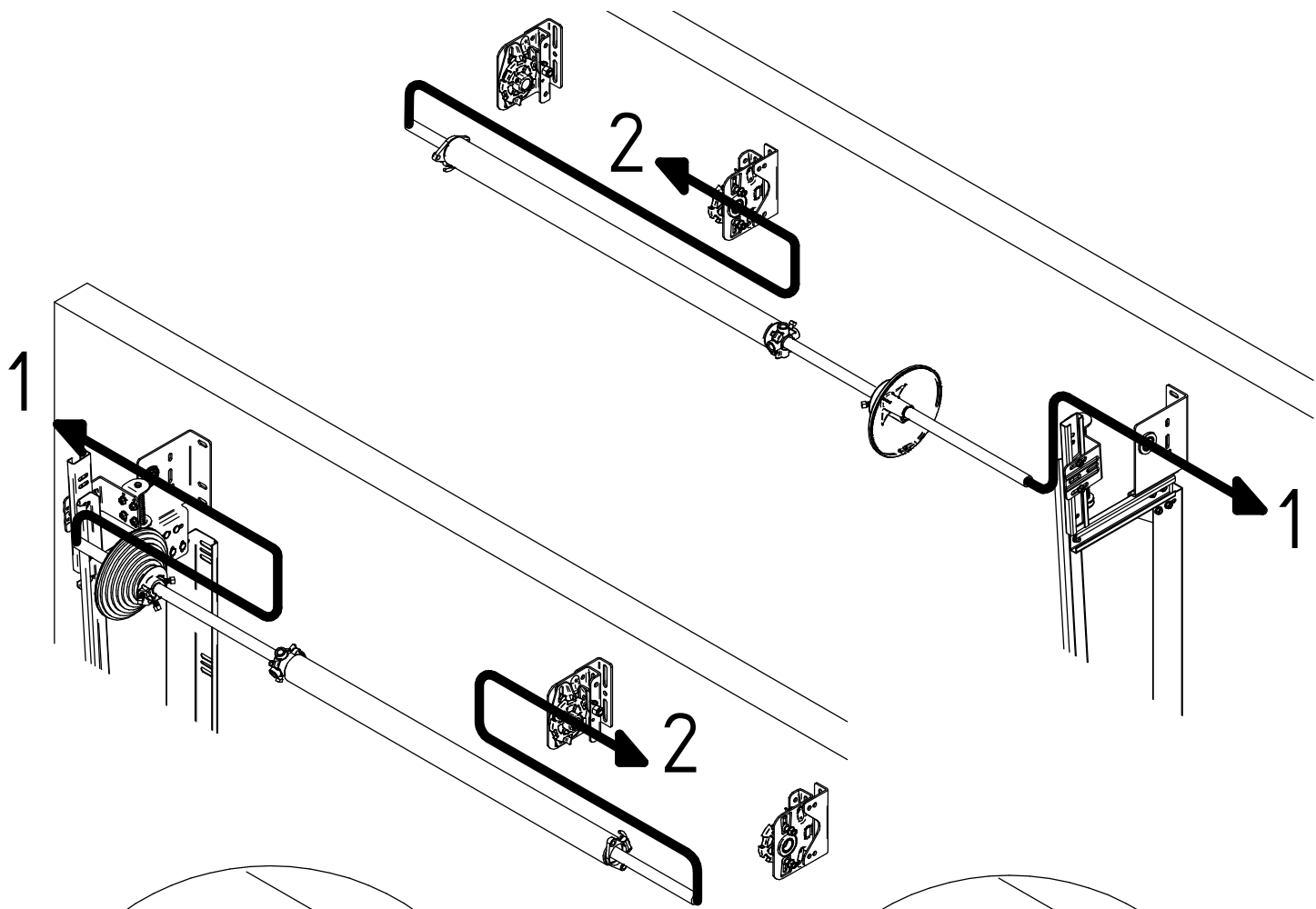

1

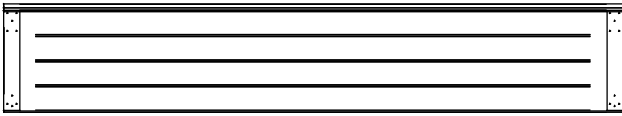

2



3

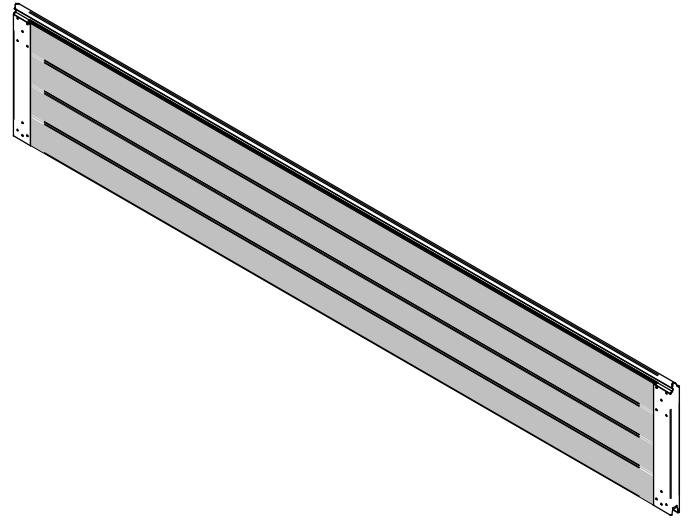
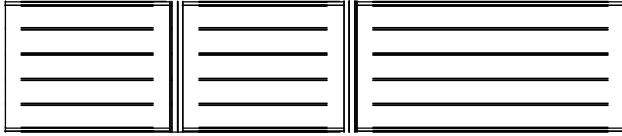

1

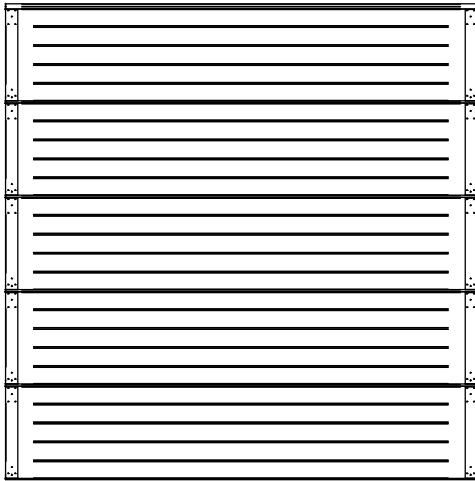

3

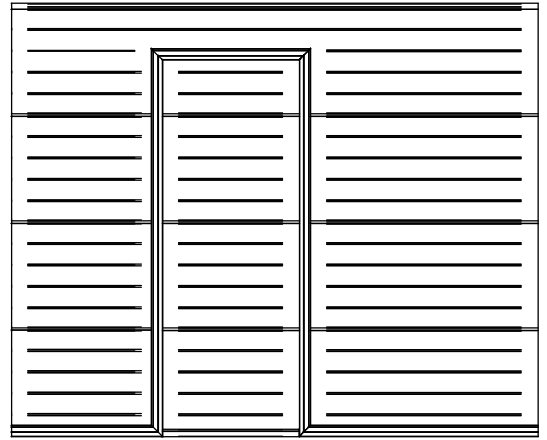

2

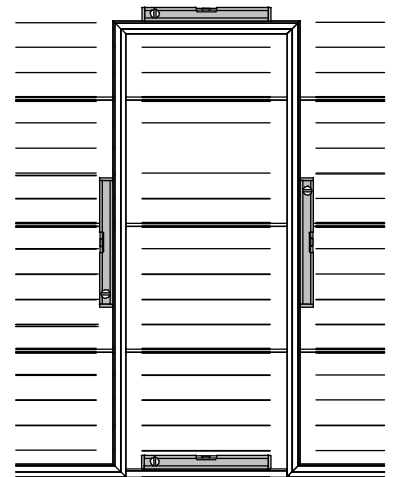
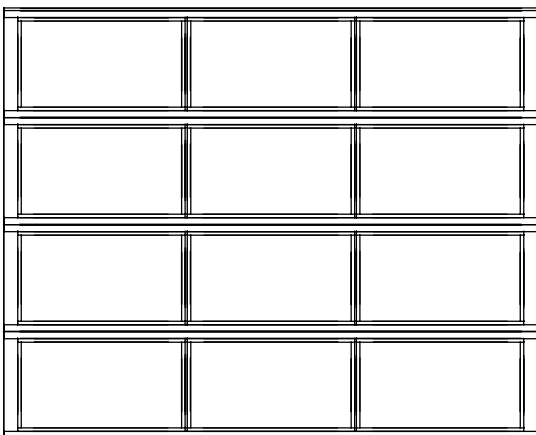

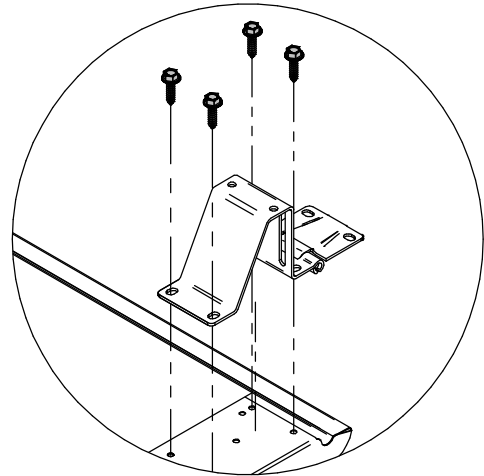
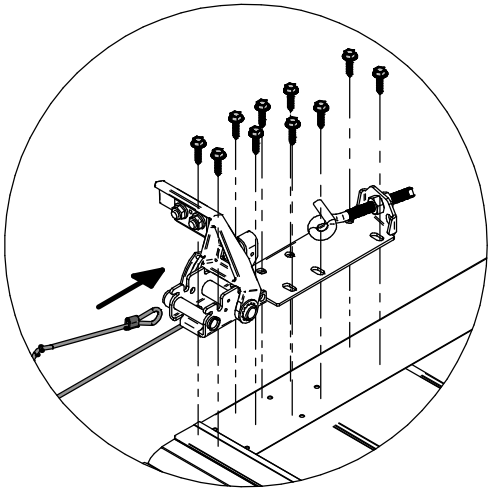
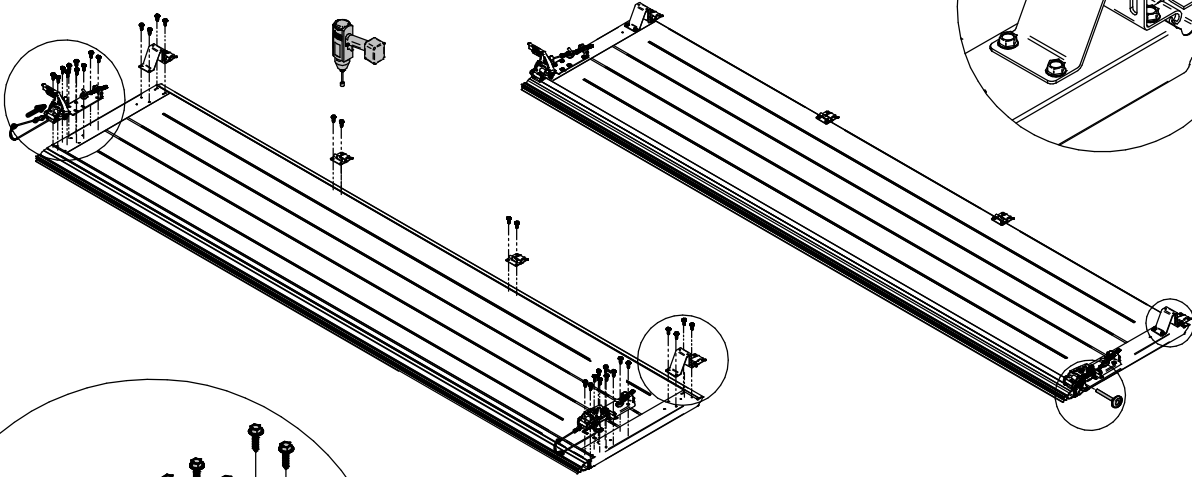
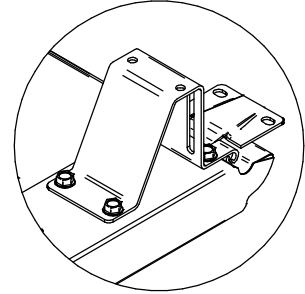
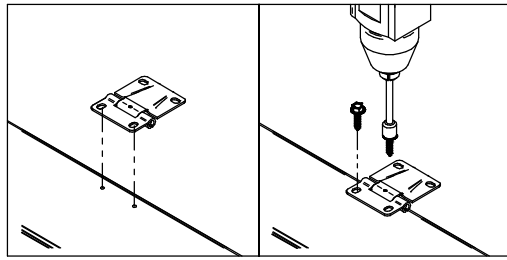
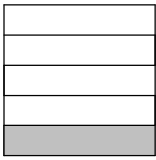

Options

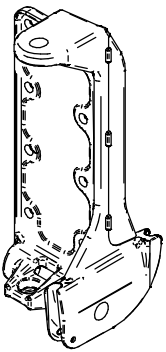

3170

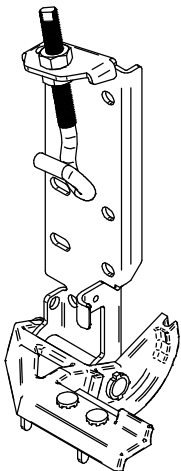

3184-3187

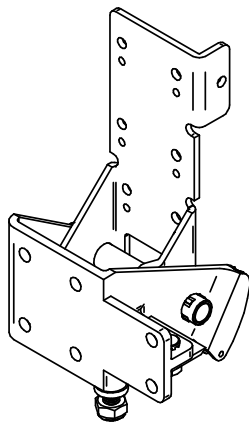

3194

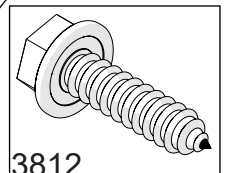
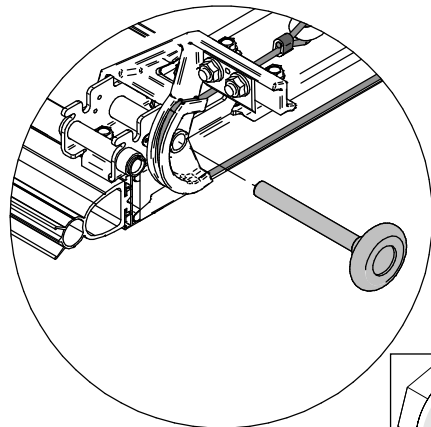

3812

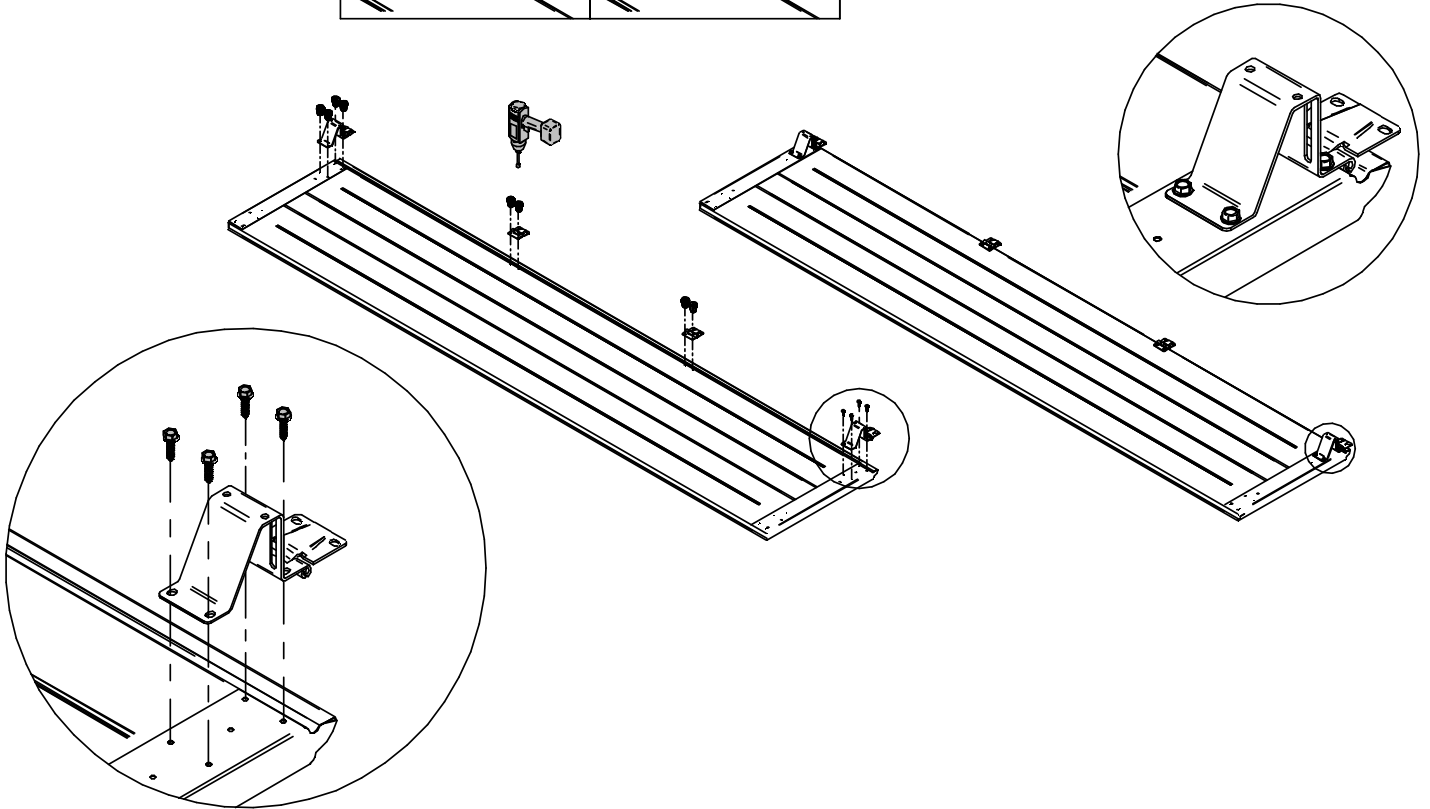
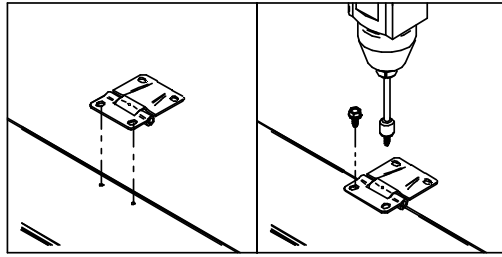

DLW \geq 5000 mm

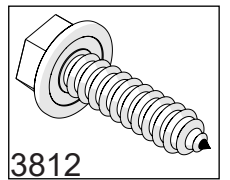
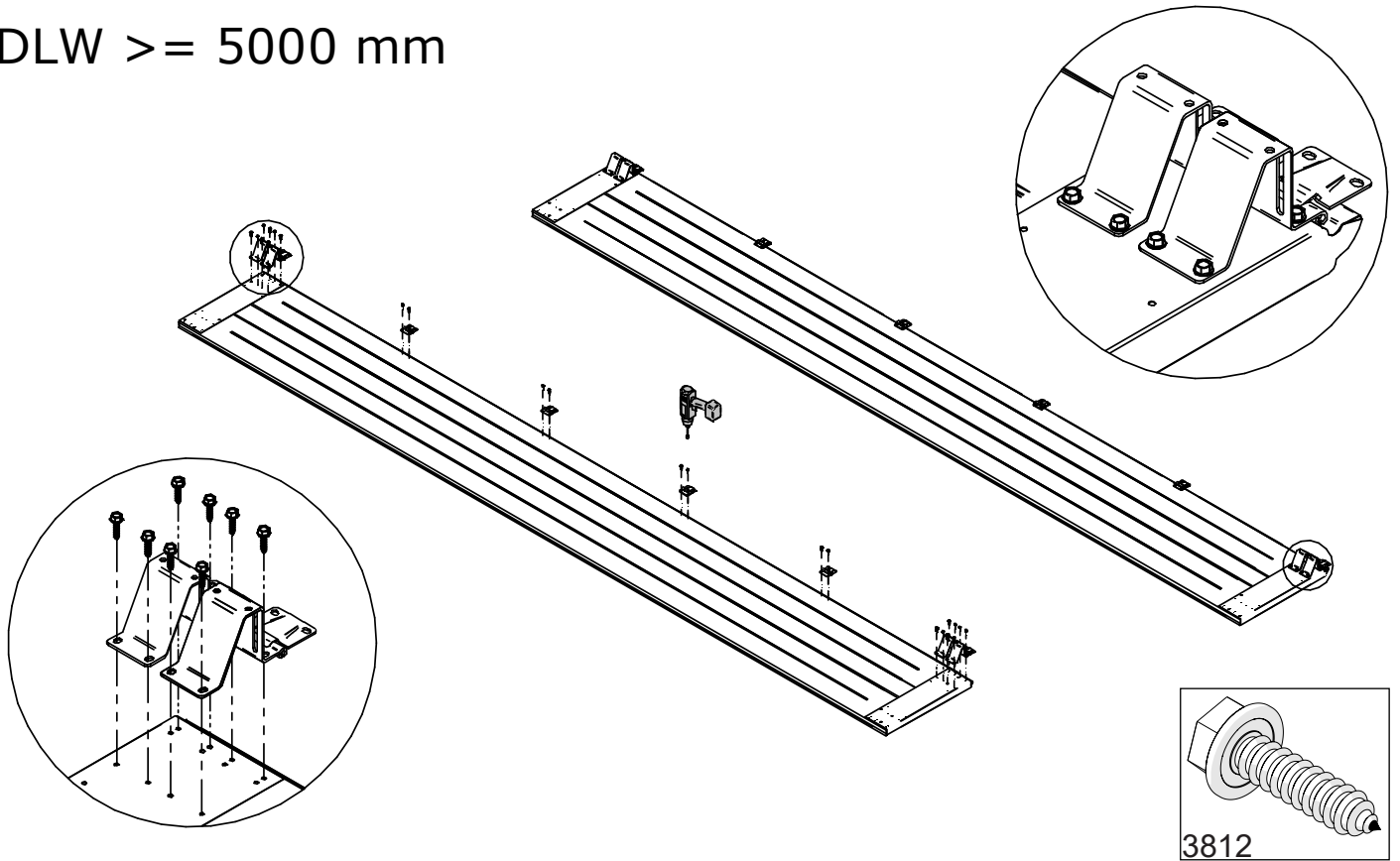

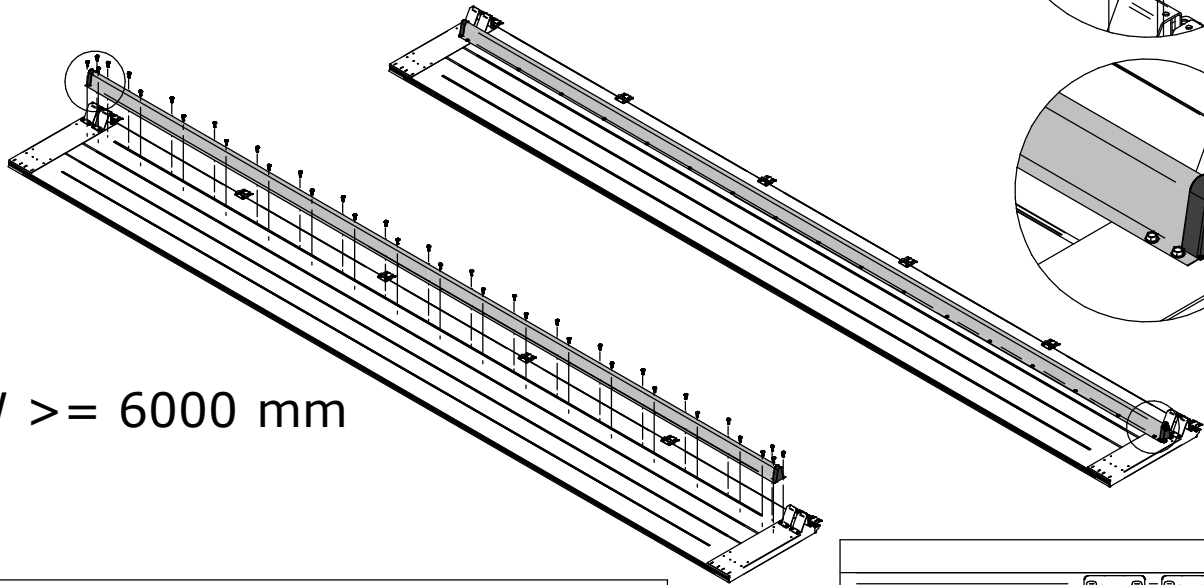
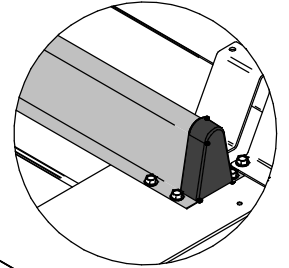
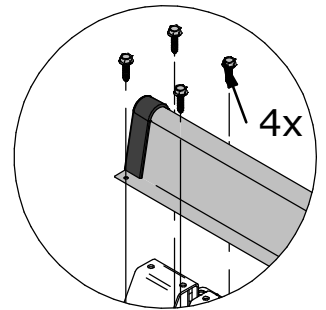
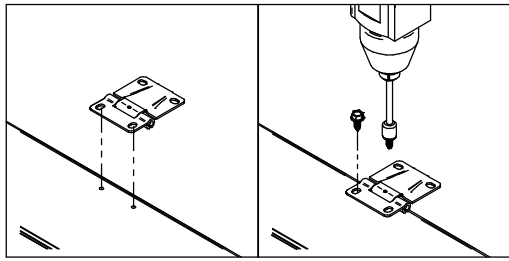
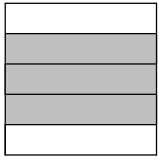

DLW \geq 6000 mm

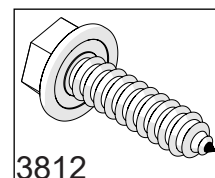
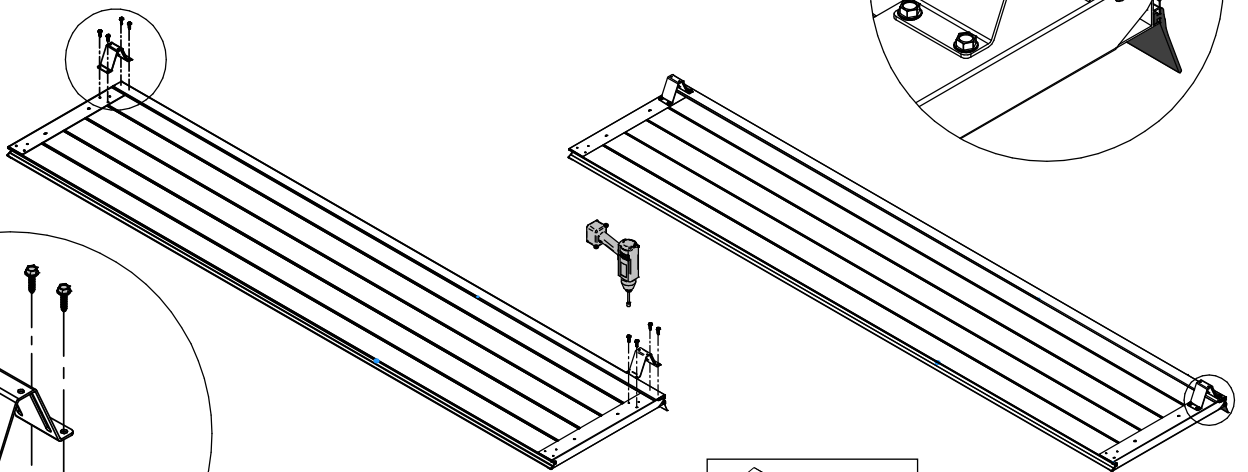
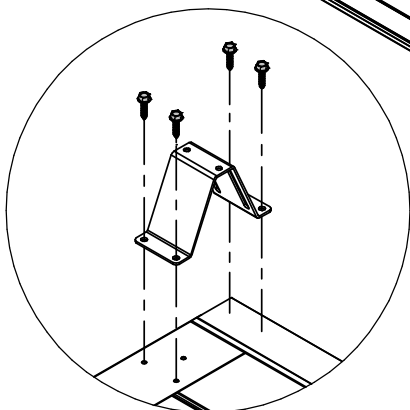
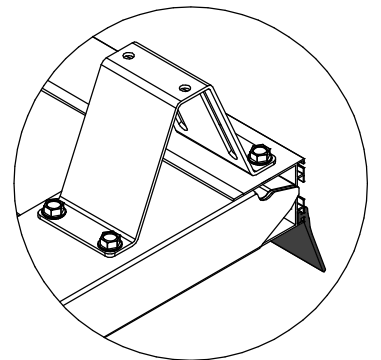
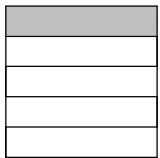
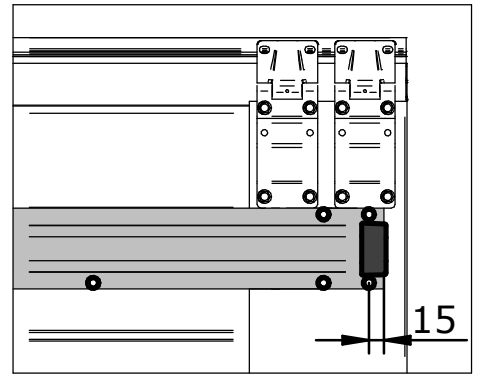
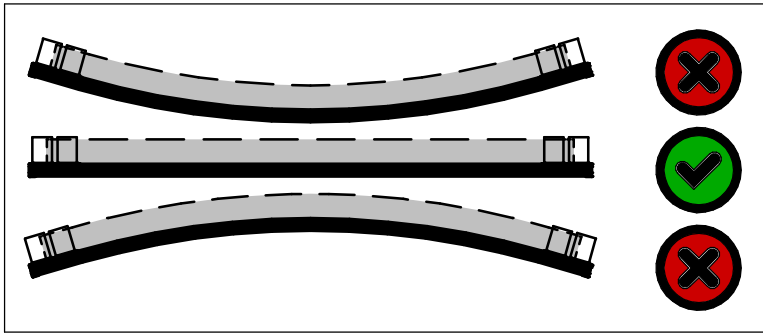

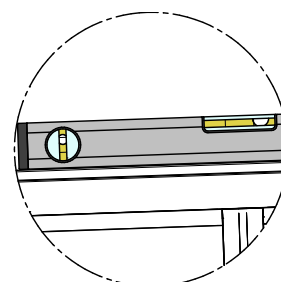
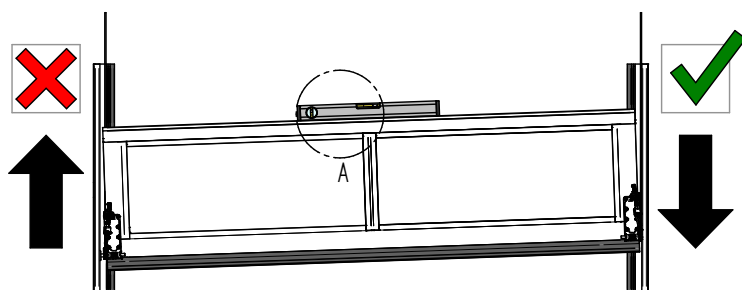
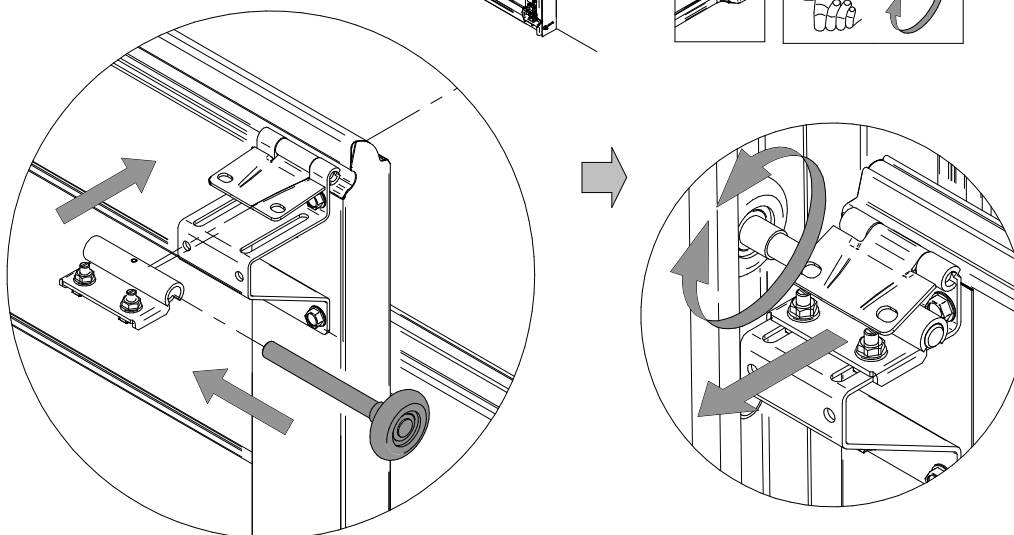
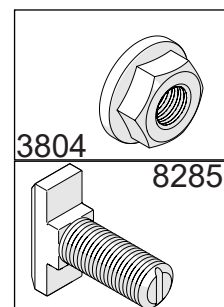
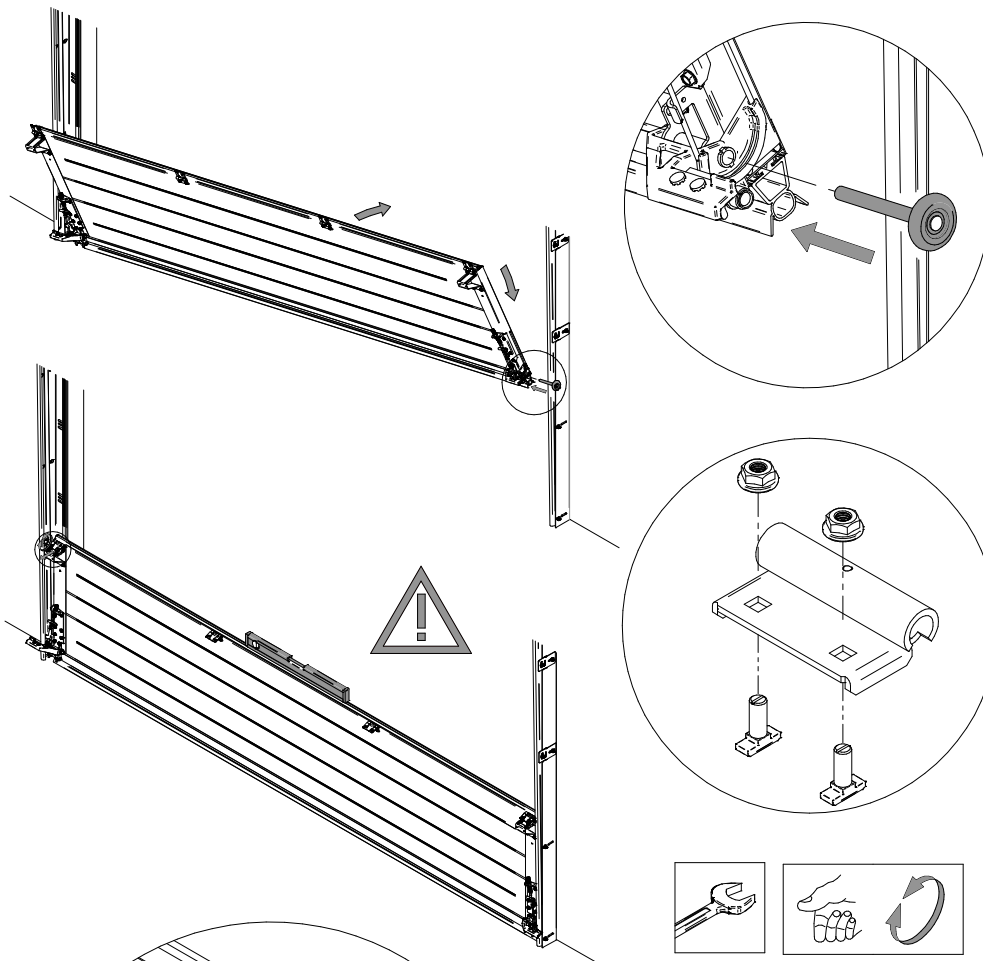

DETAIL A

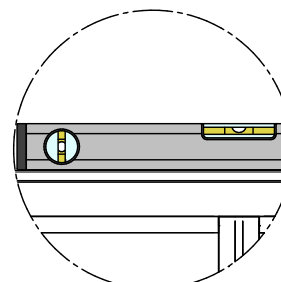
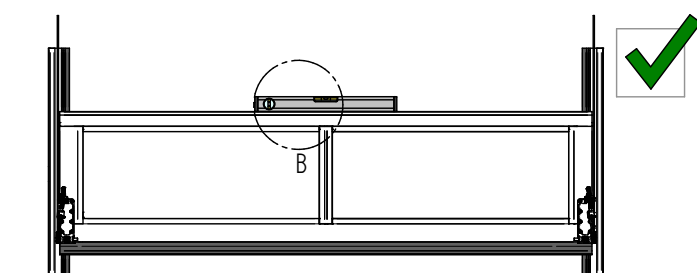

DETAIL B

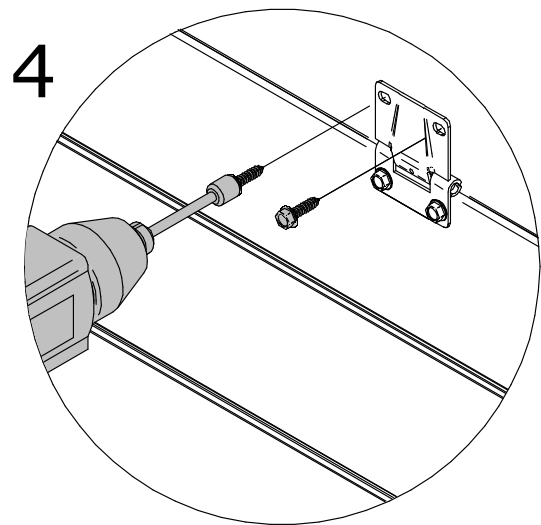
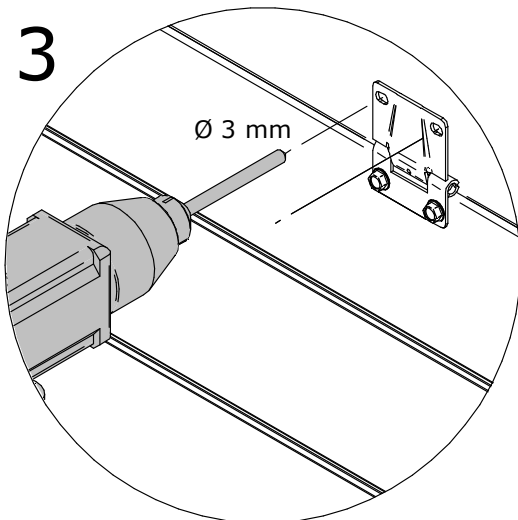
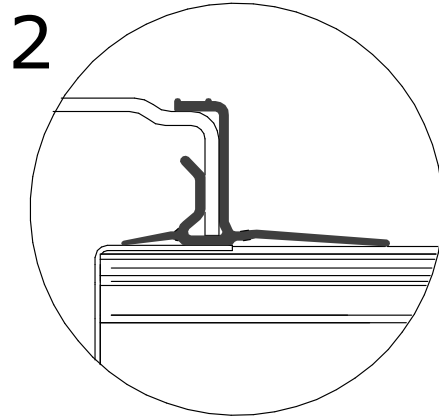
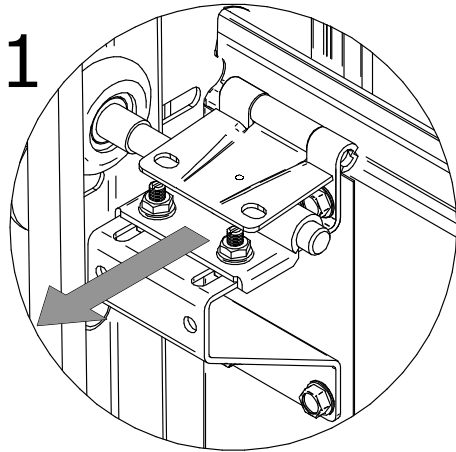
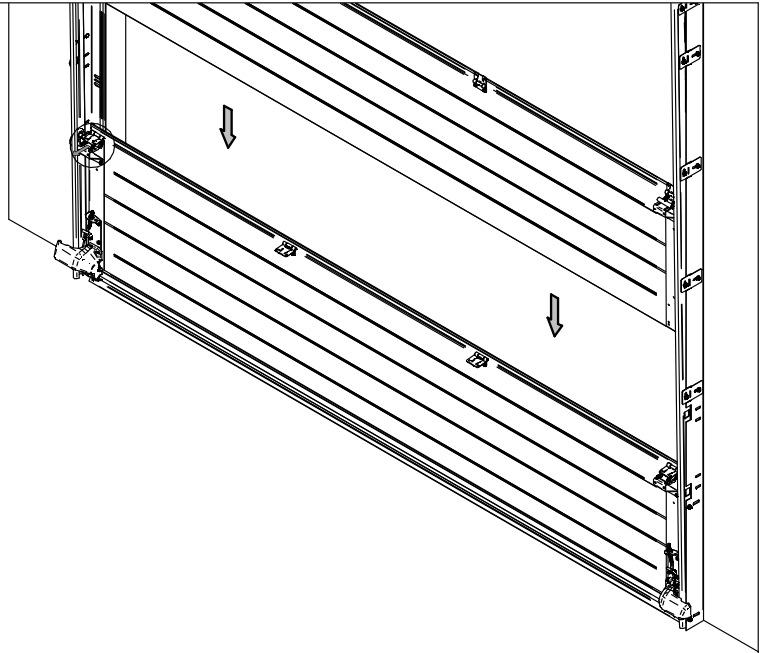
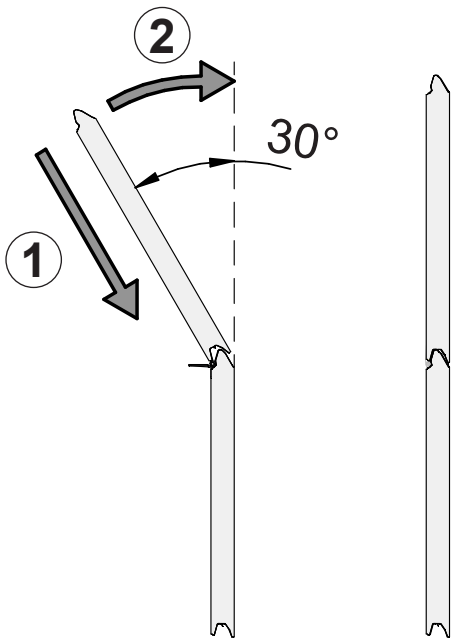

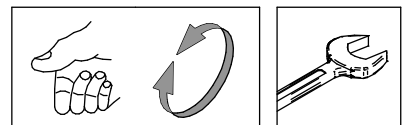
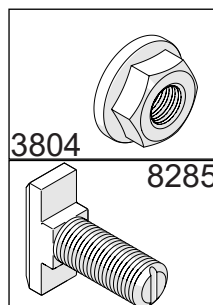
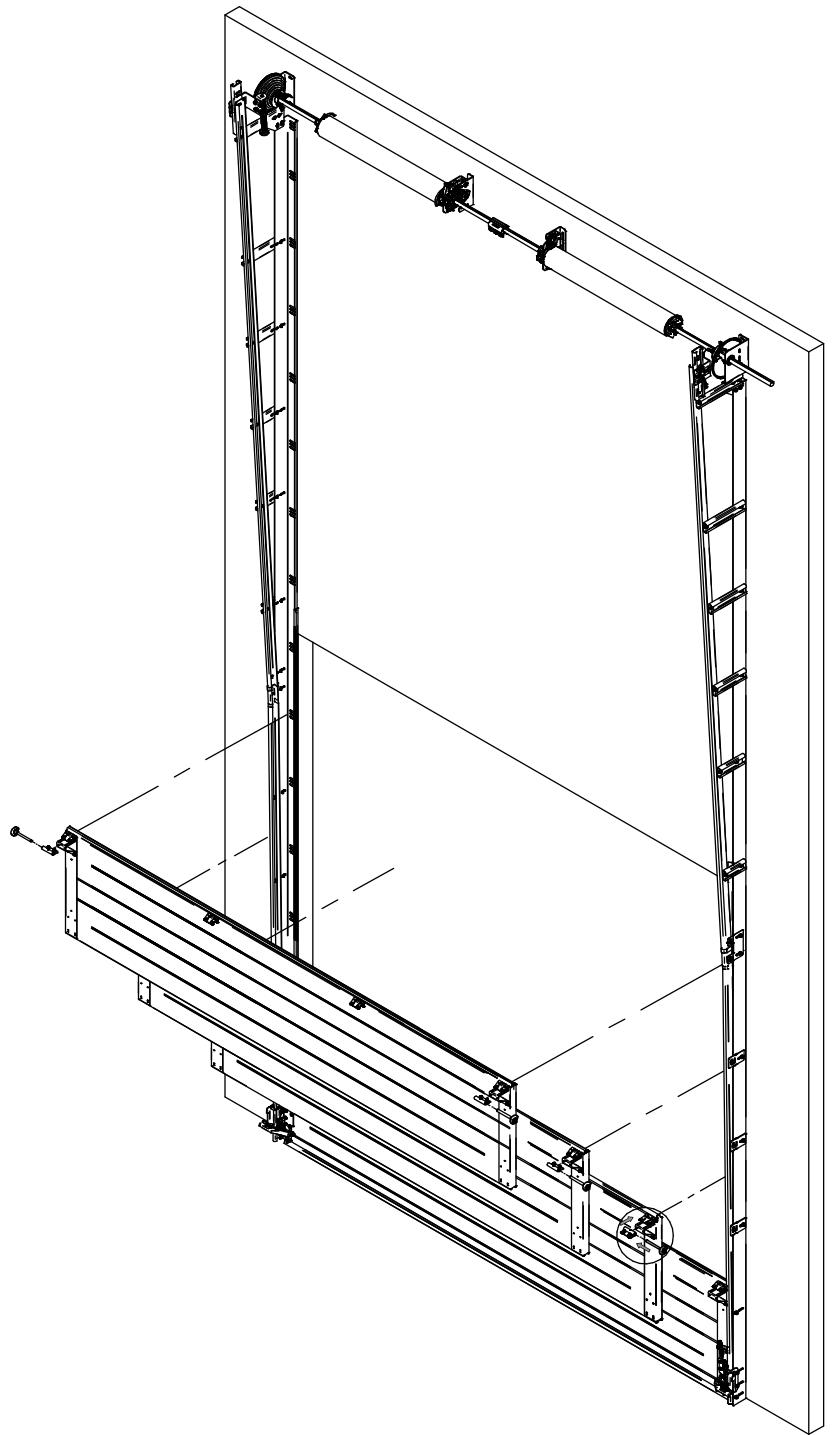
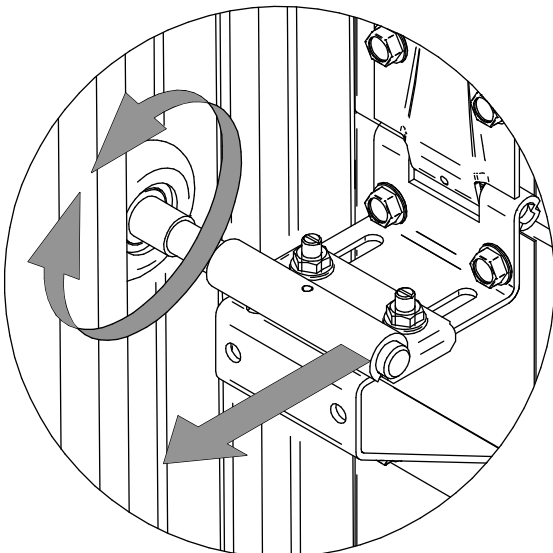
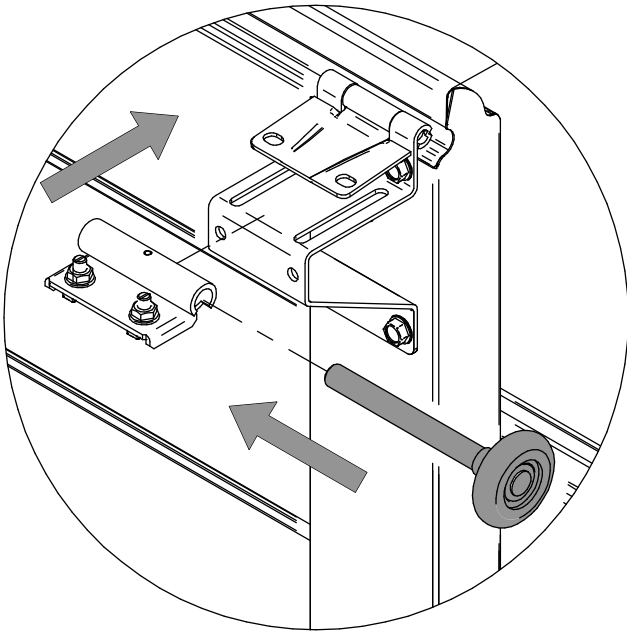
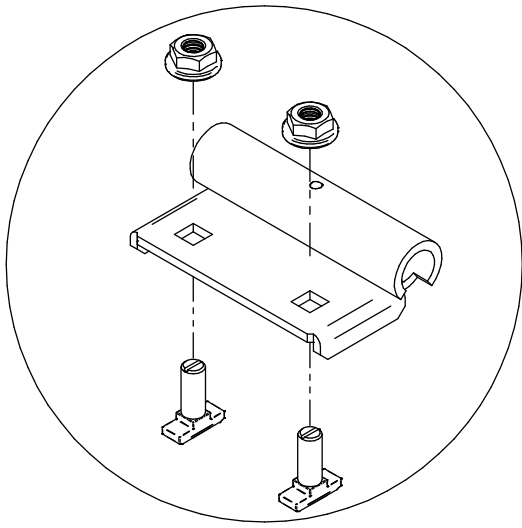

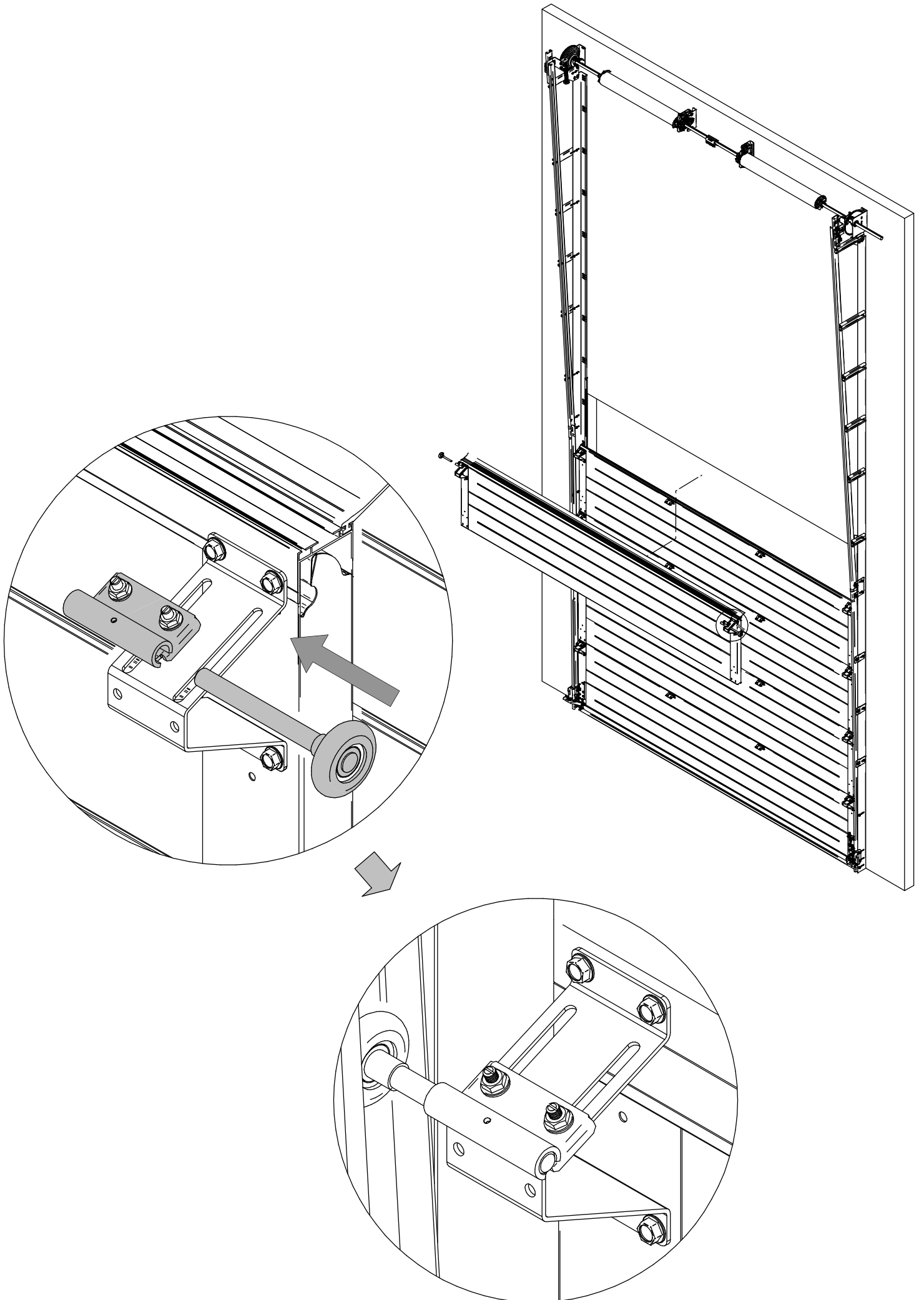

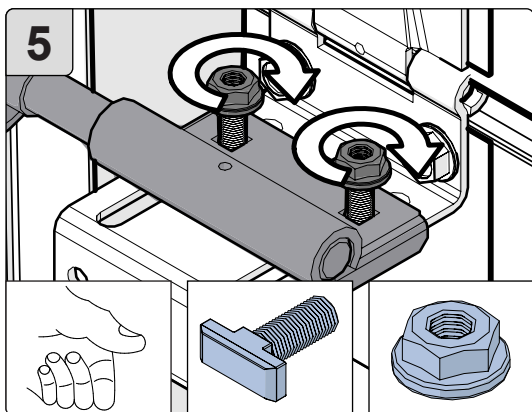
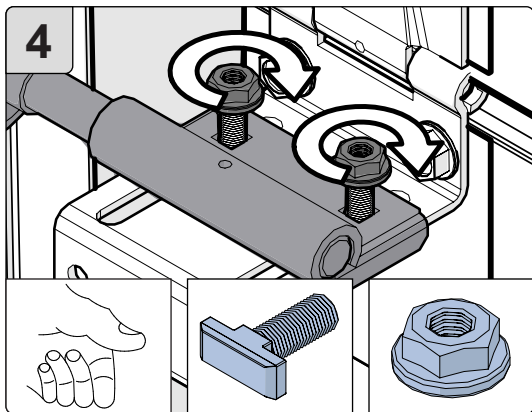
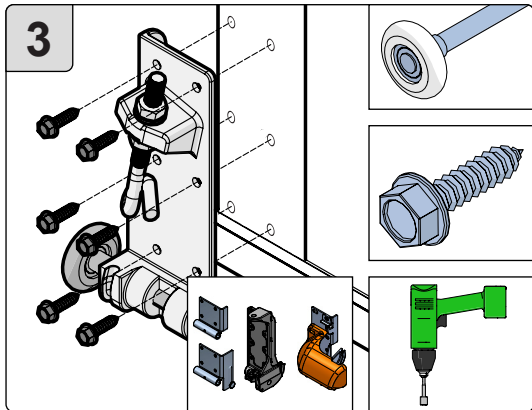
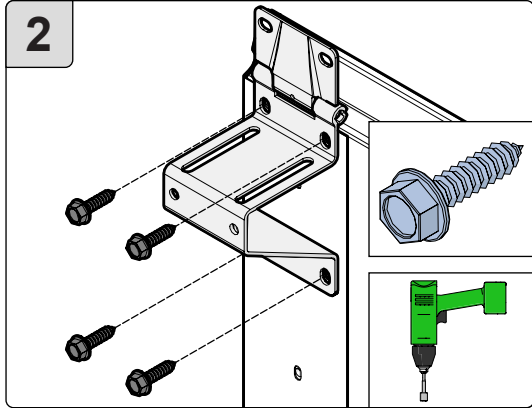
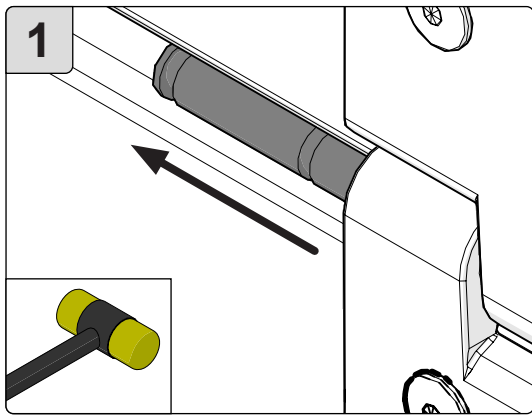

OPTION

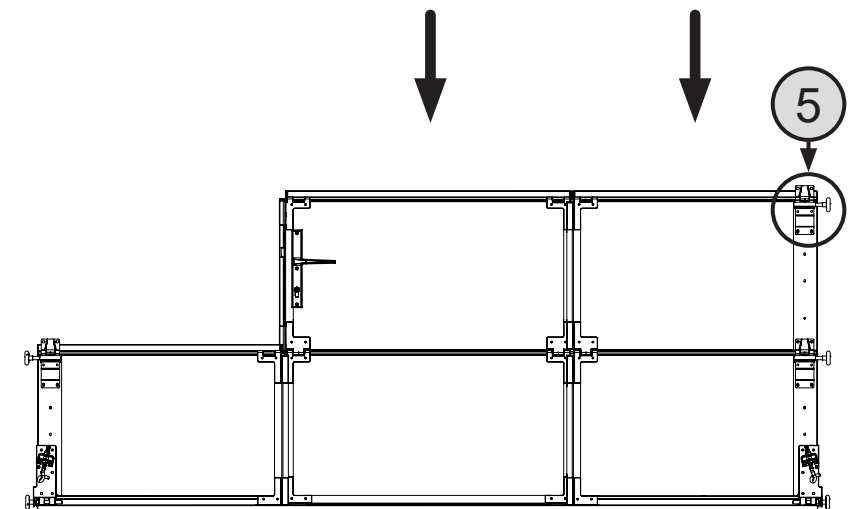
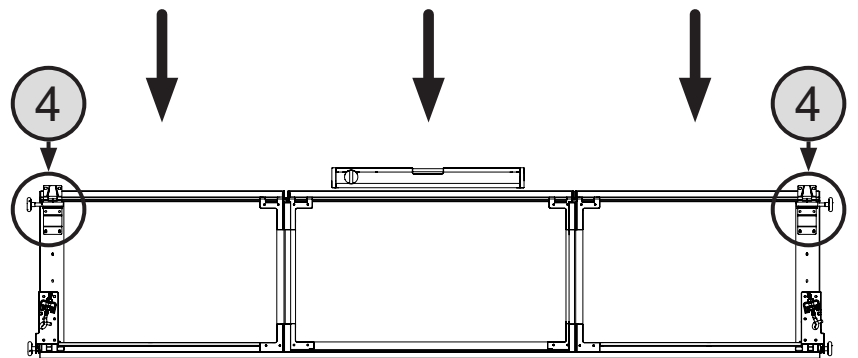
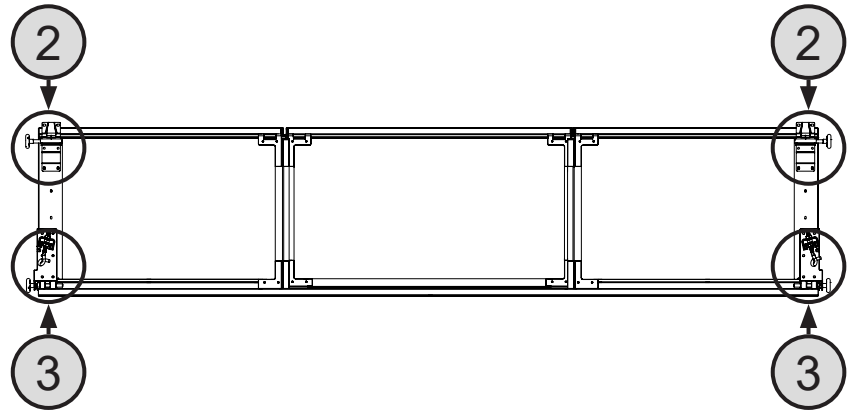

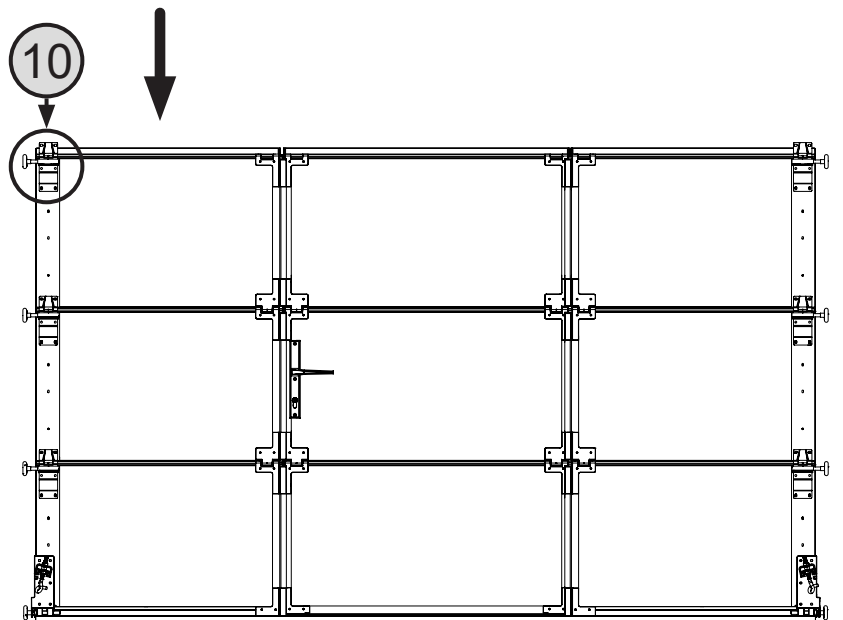
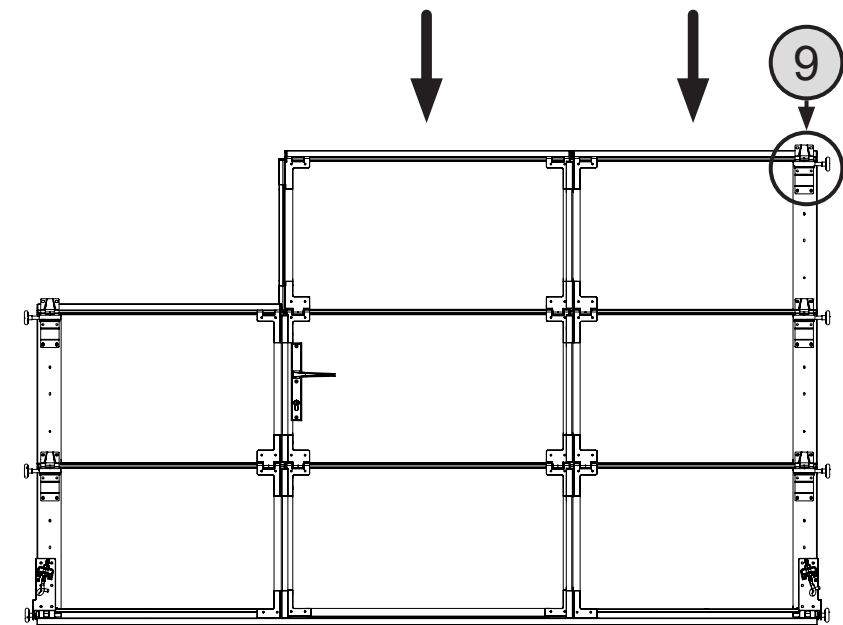
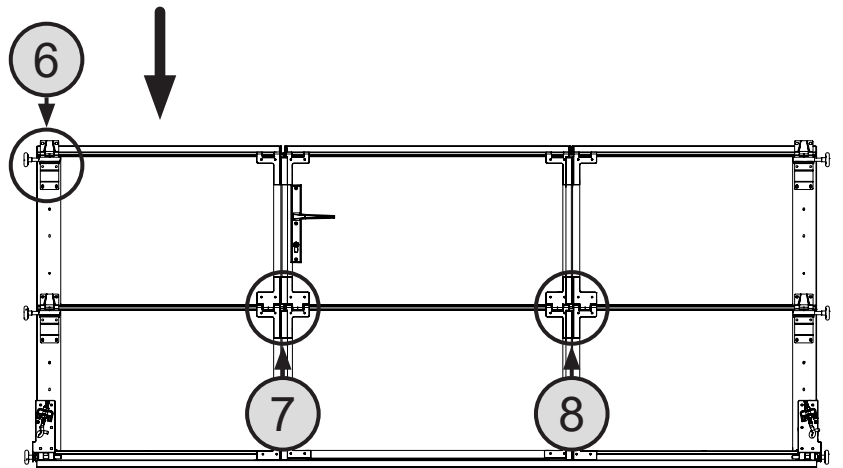
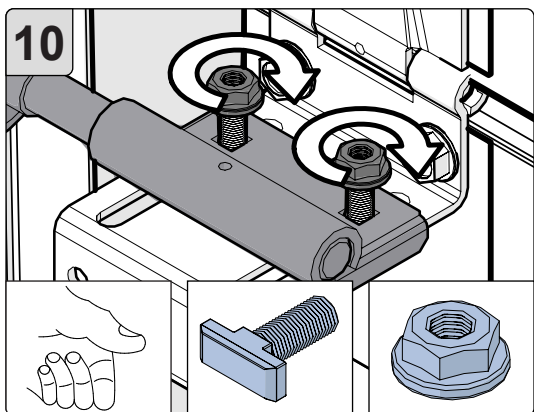
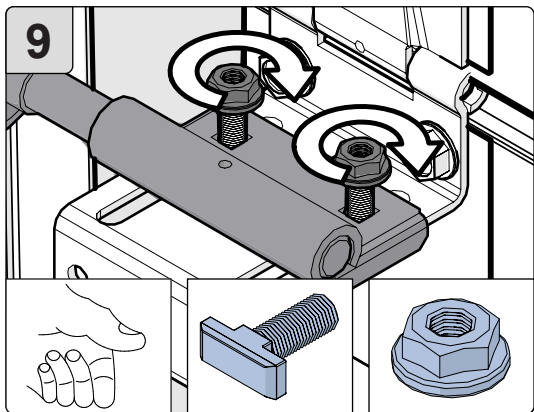
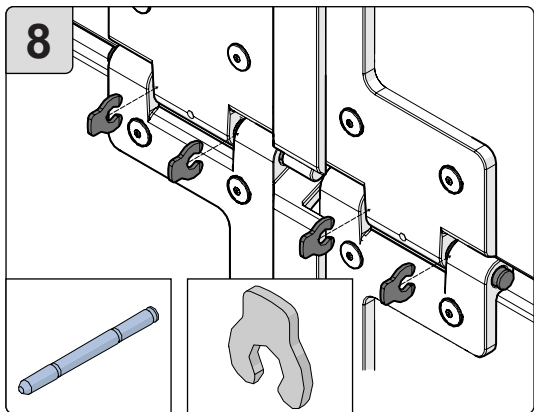
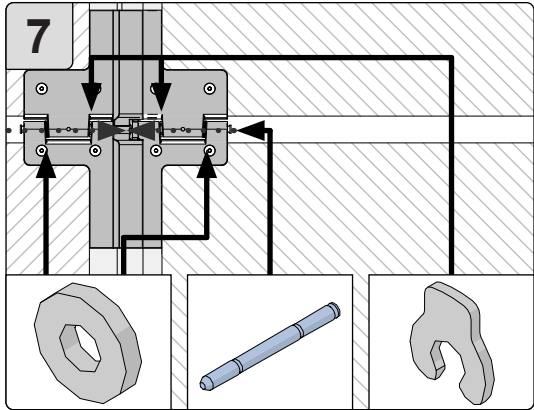
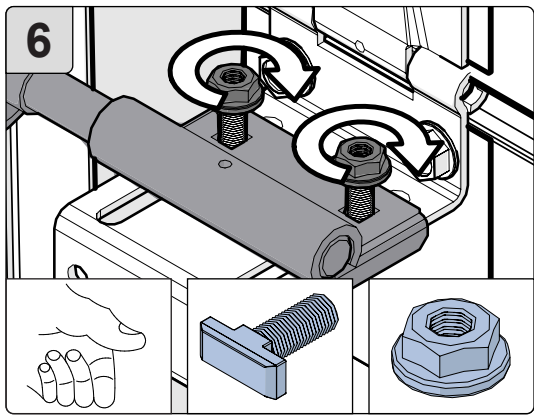

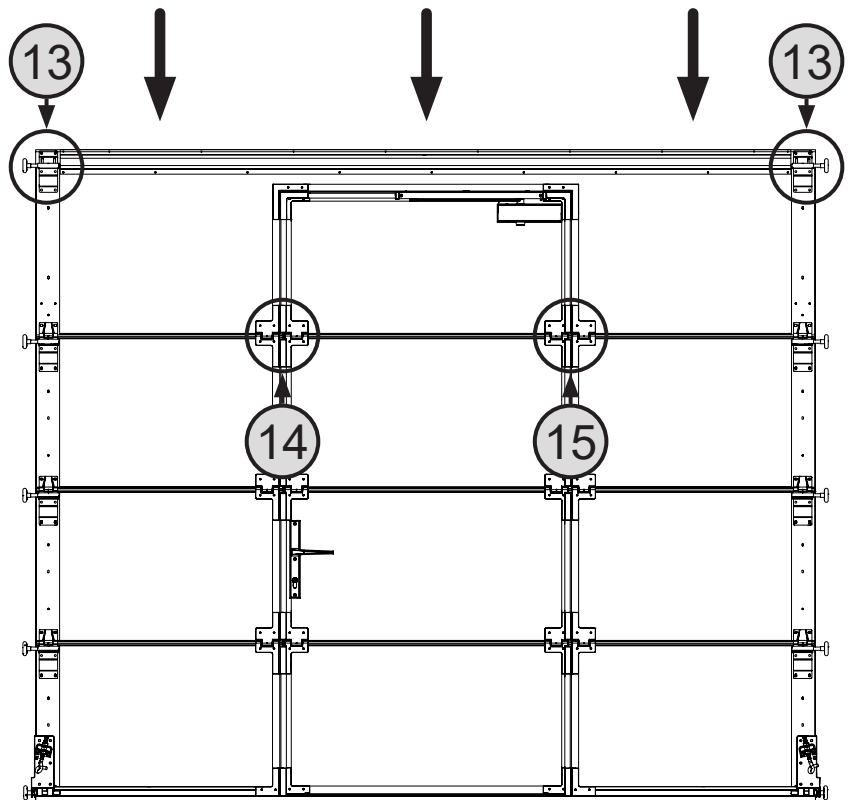
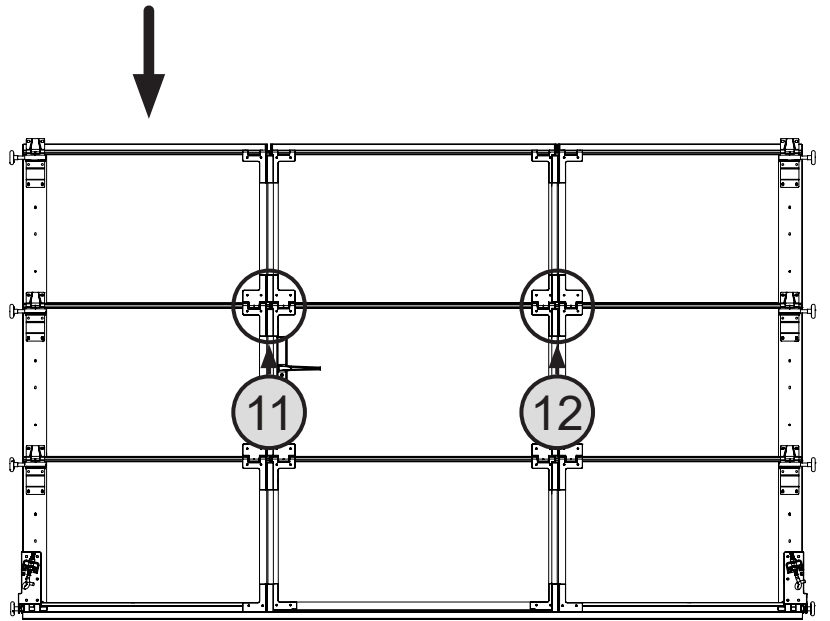
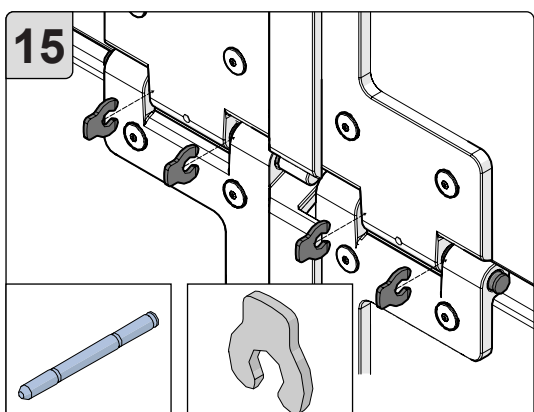
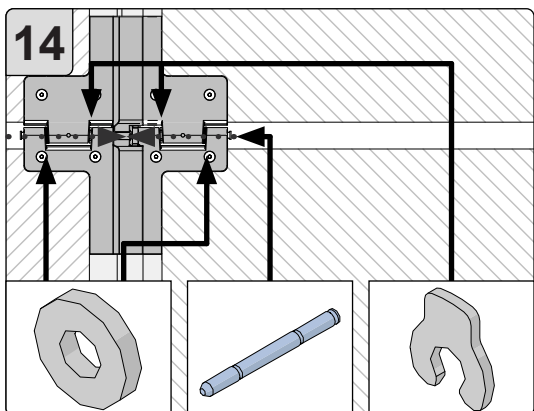
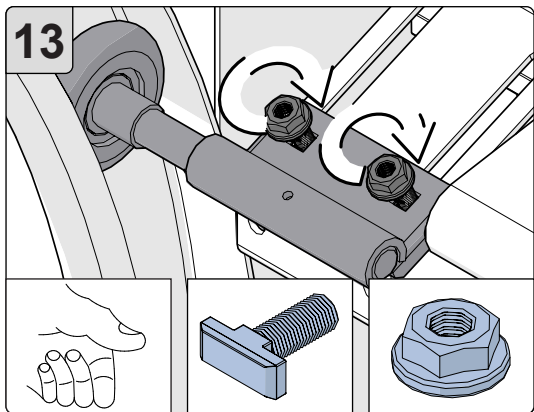
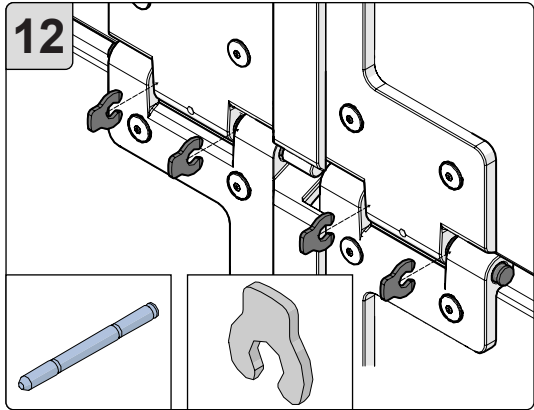
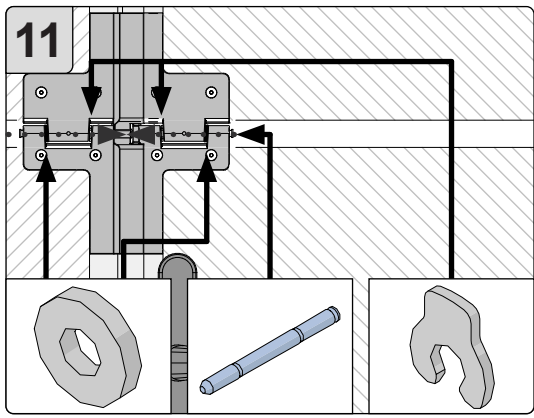

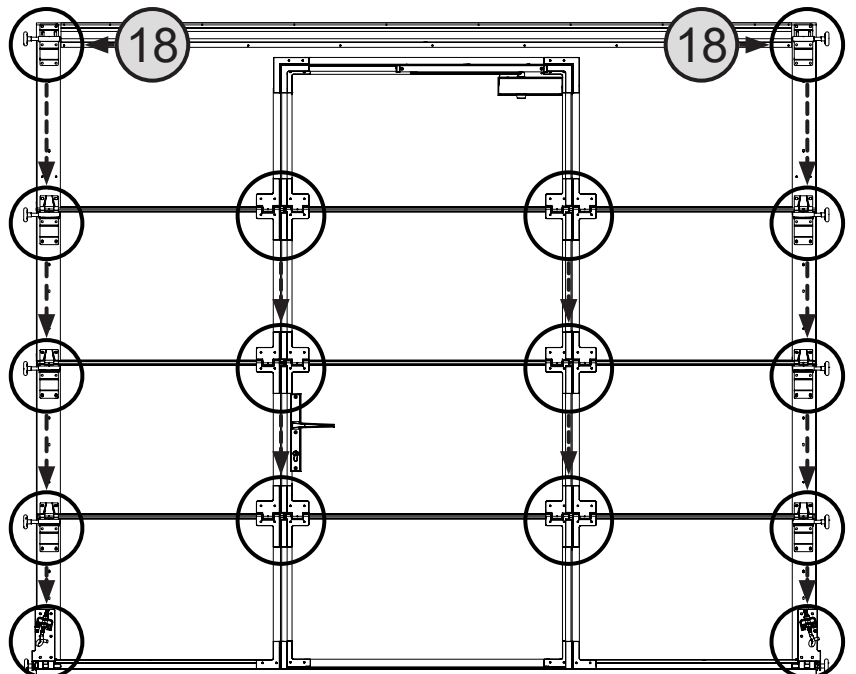
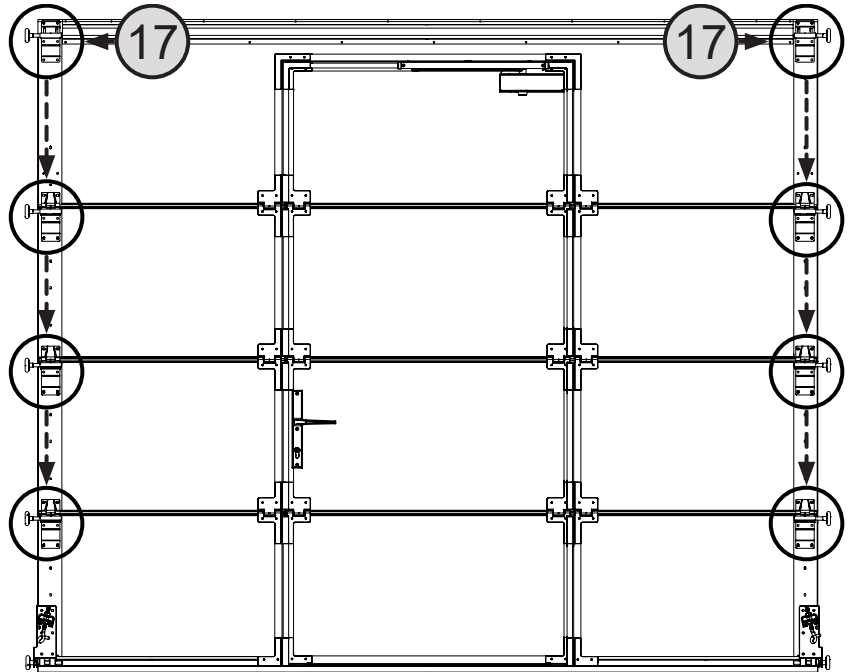
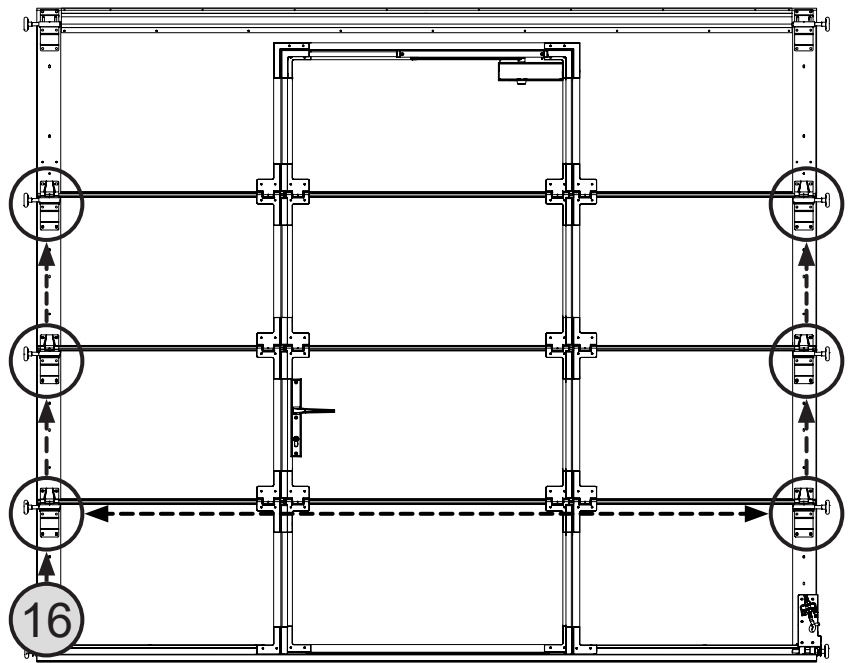
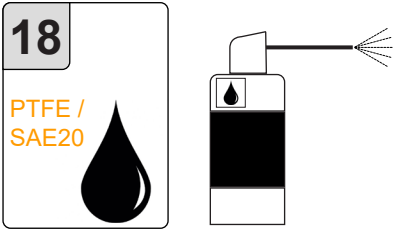
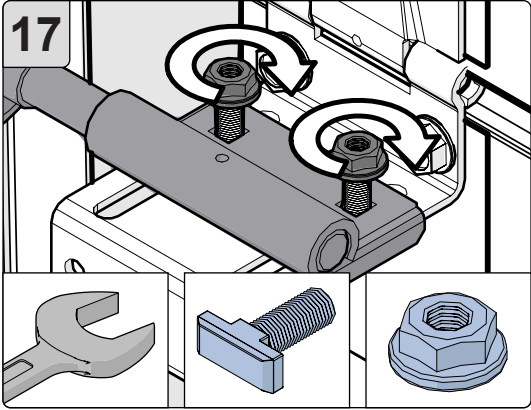
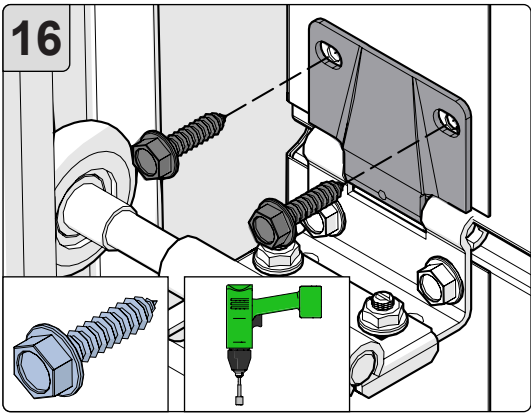

Option
Optie

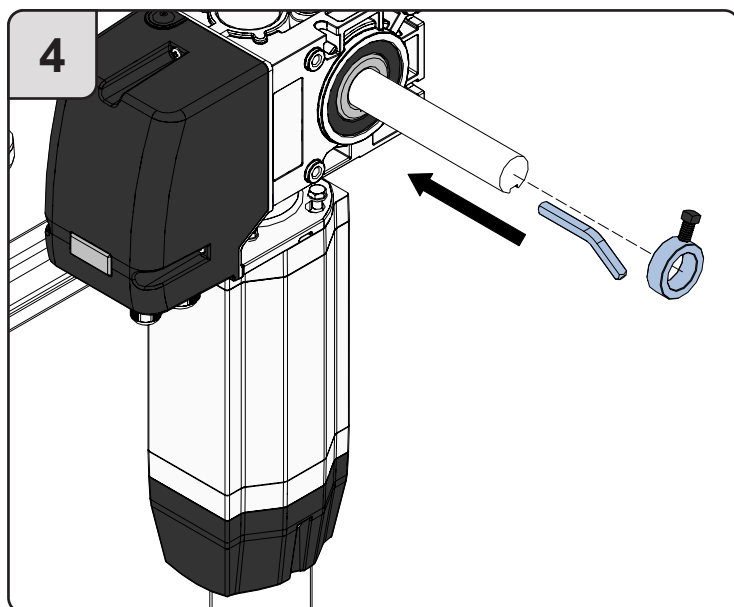
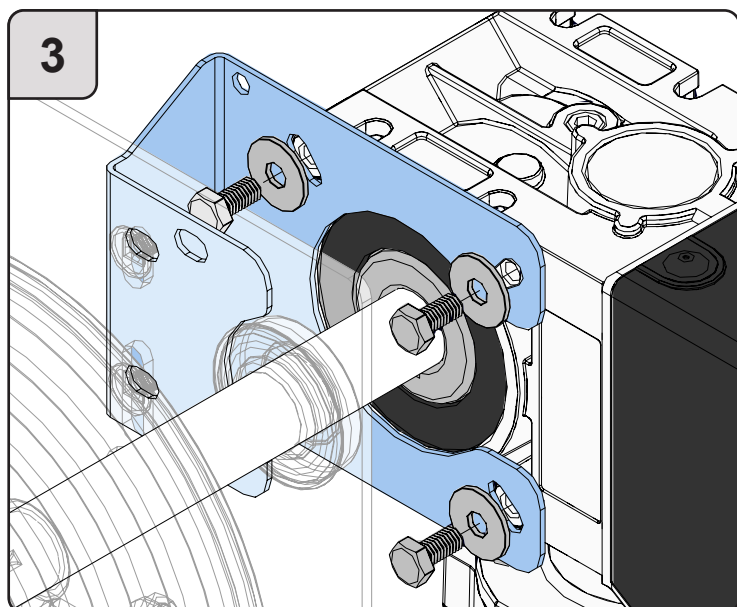
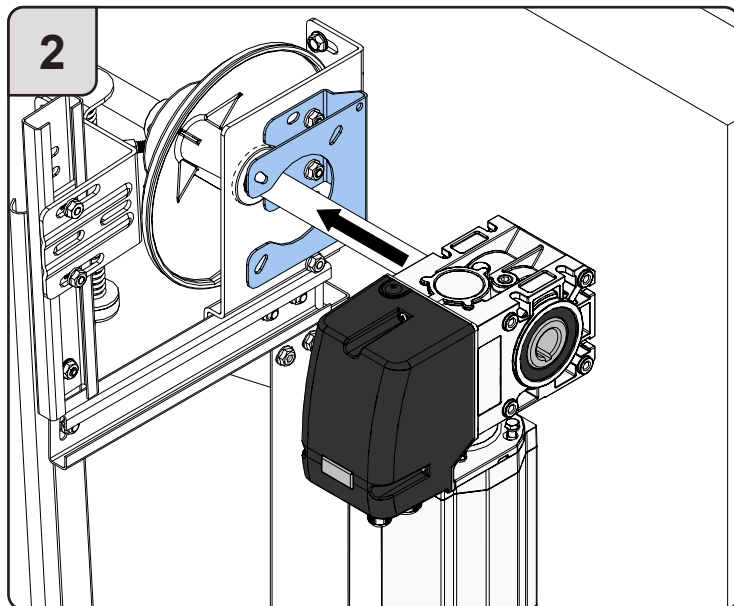
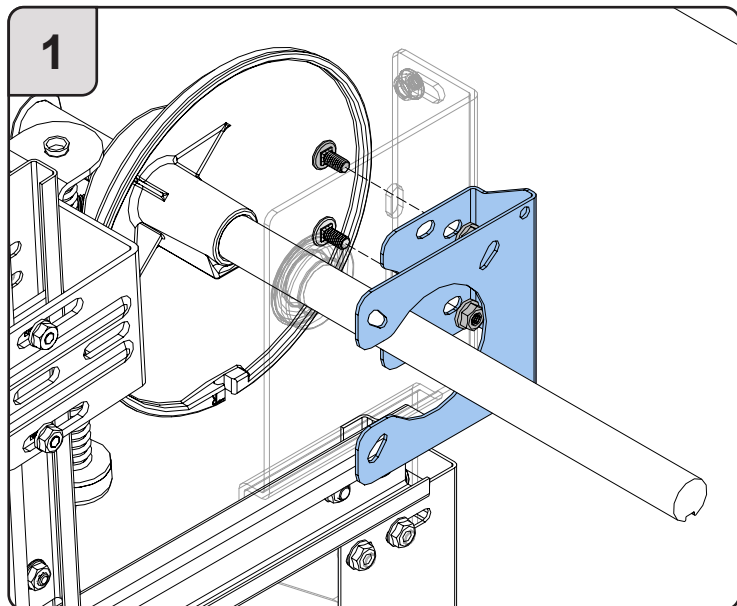

Option / Optie

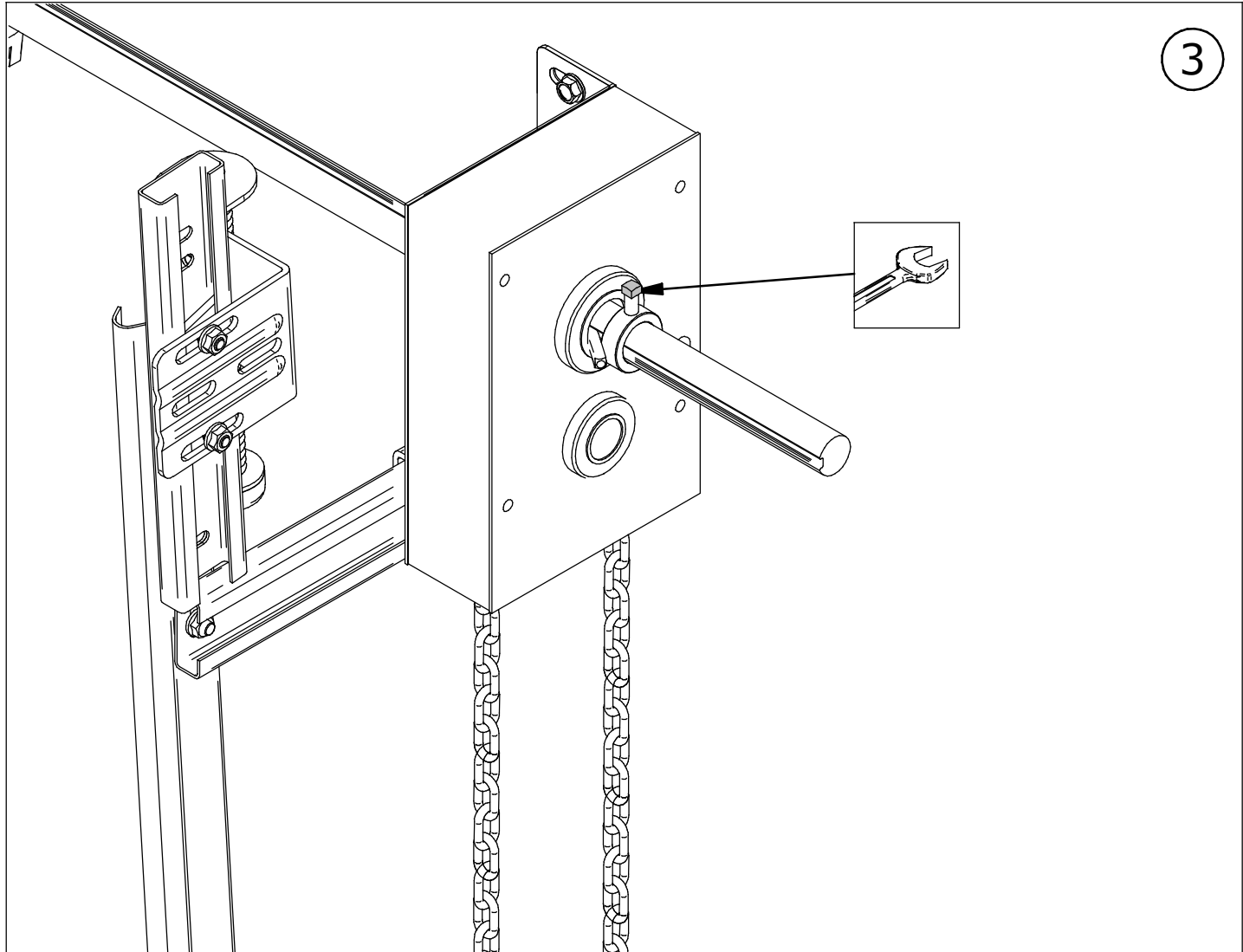
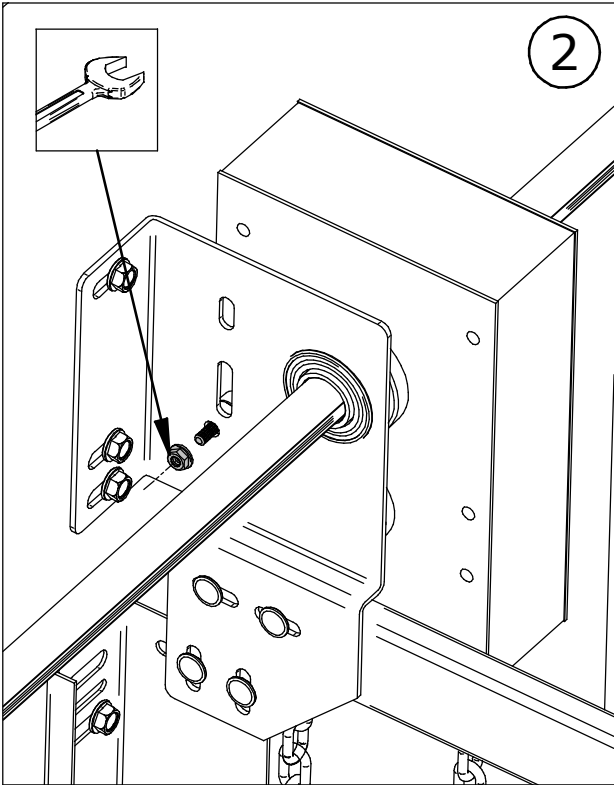
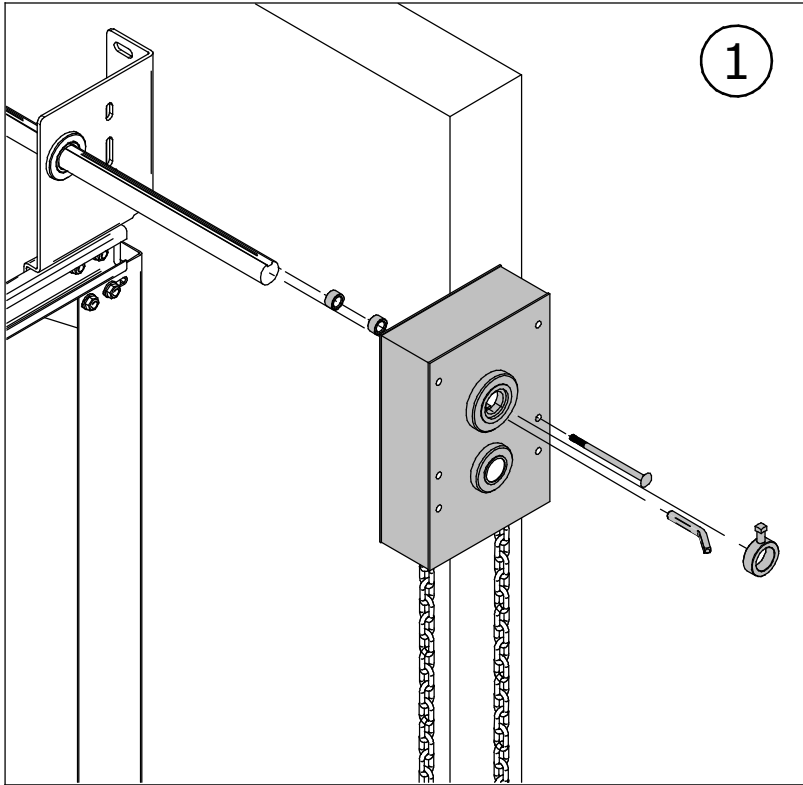

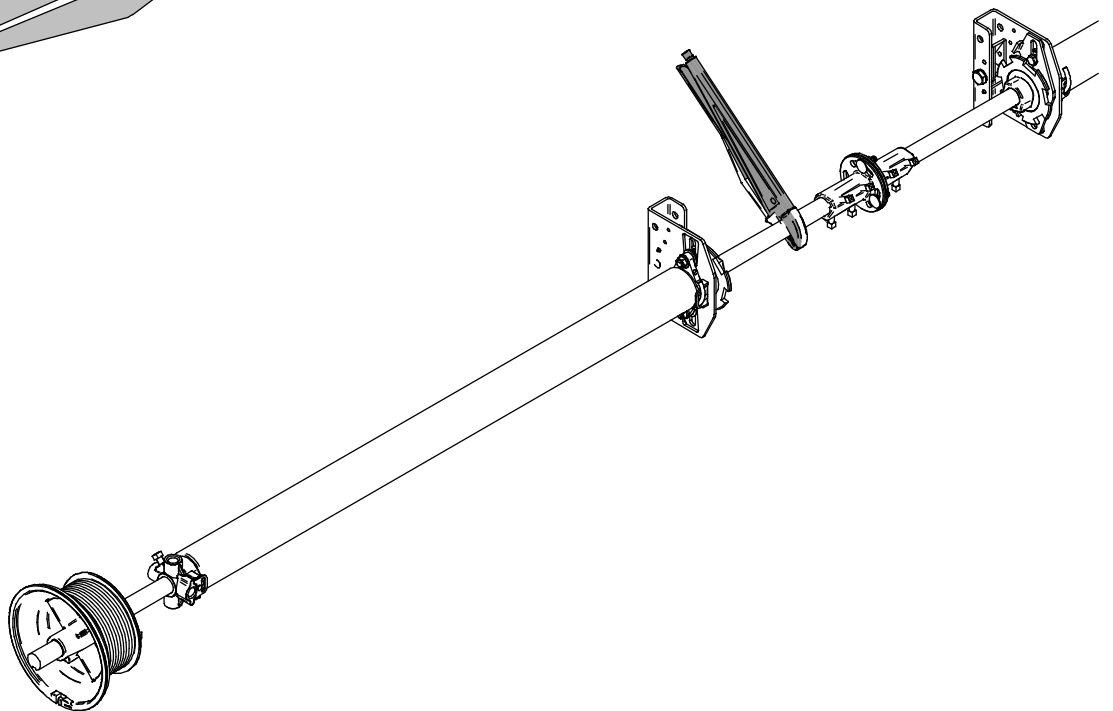
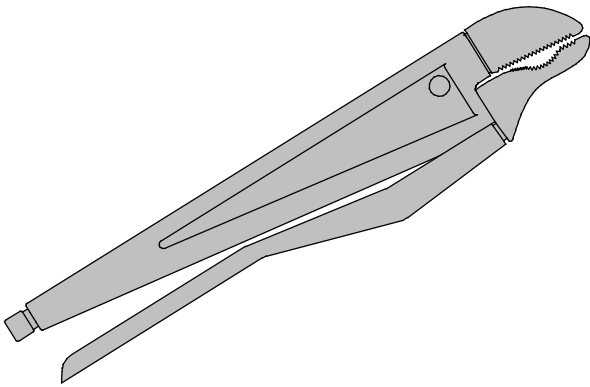
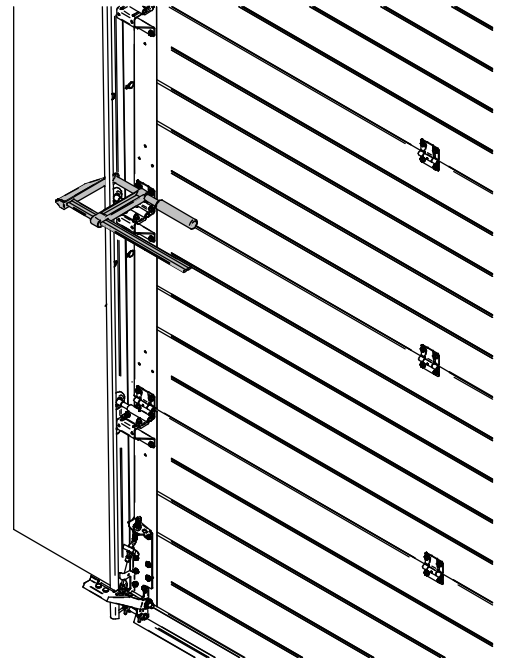
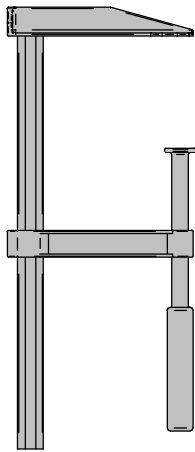

1

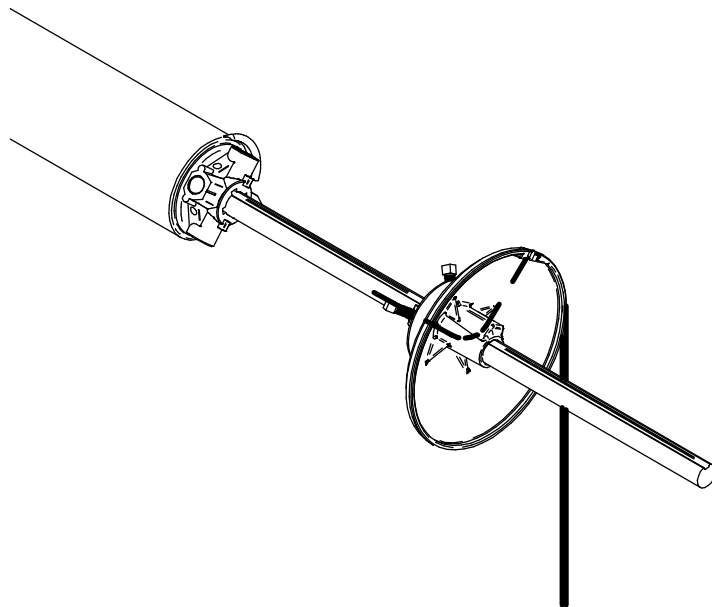
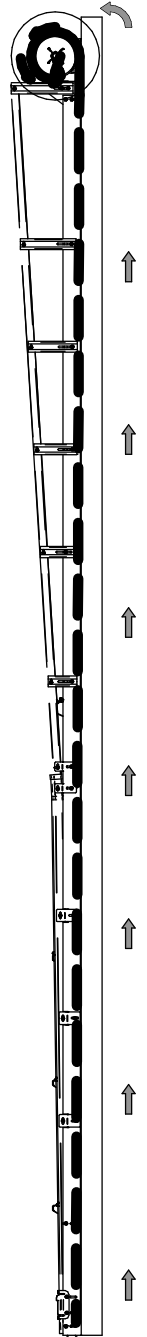
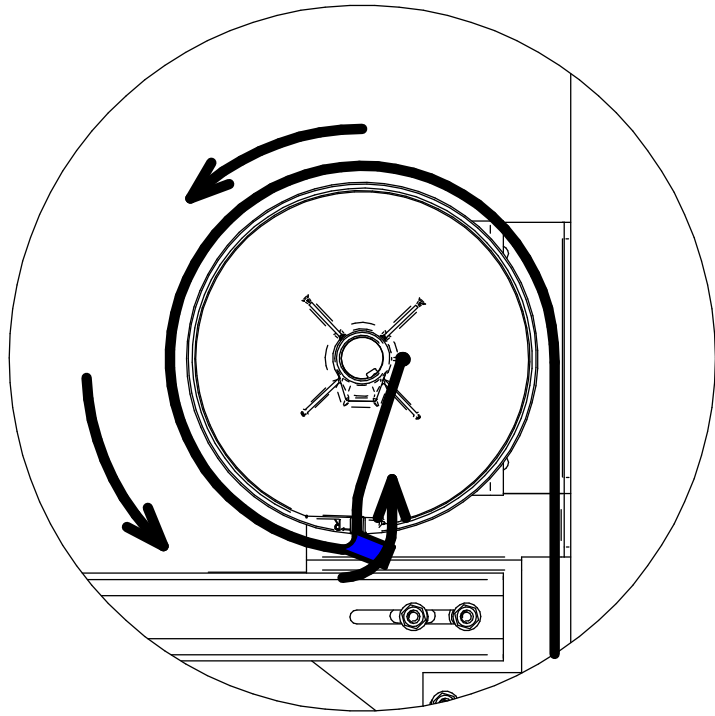
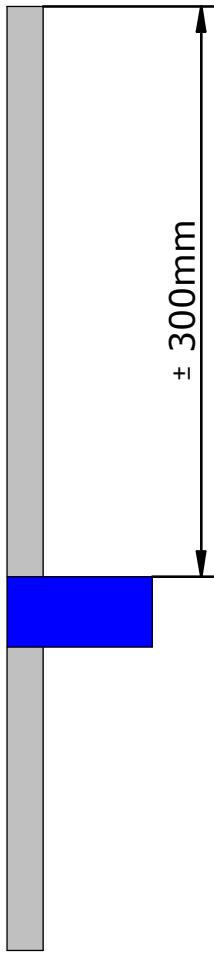

2

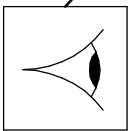
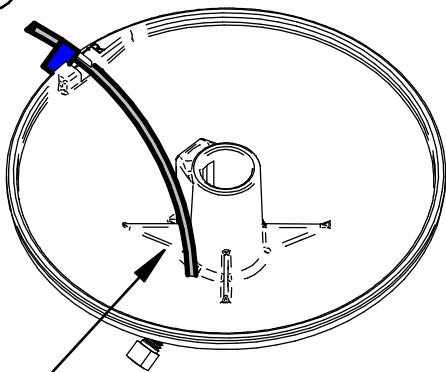

3

- $\frac{1}{2}$ x Veiligheidswinding
- $\frac{1}{2}$ x Sicherheitswickelung
- $\frac{1}{2}$ x Safety wind
- $\frac{1}{2}$ x Tour de sécurité

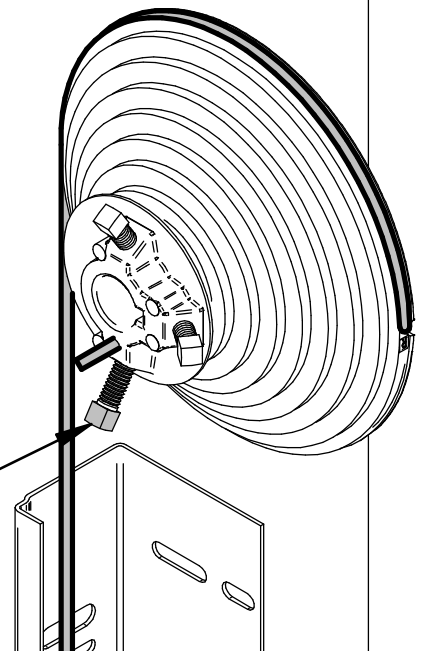
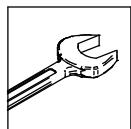

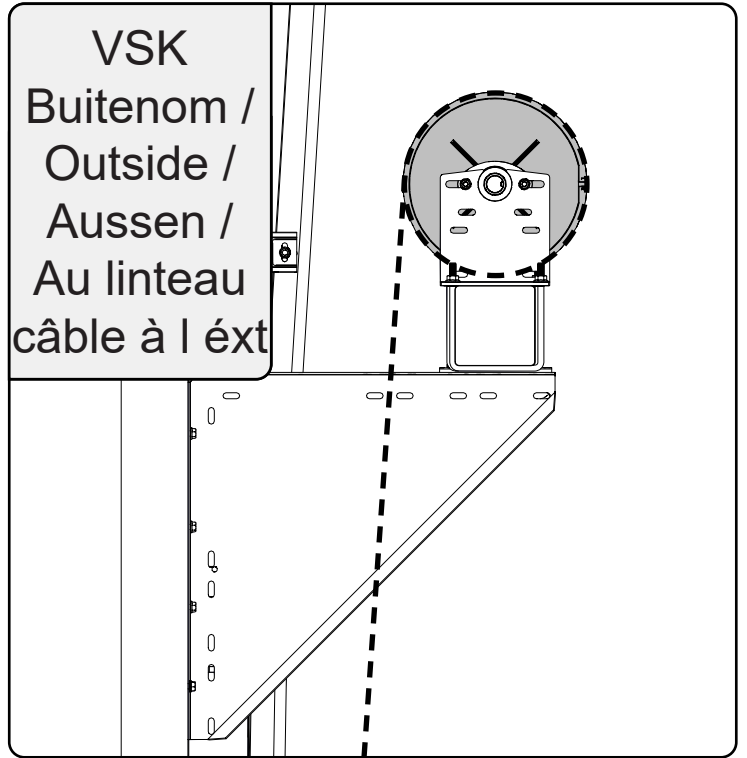
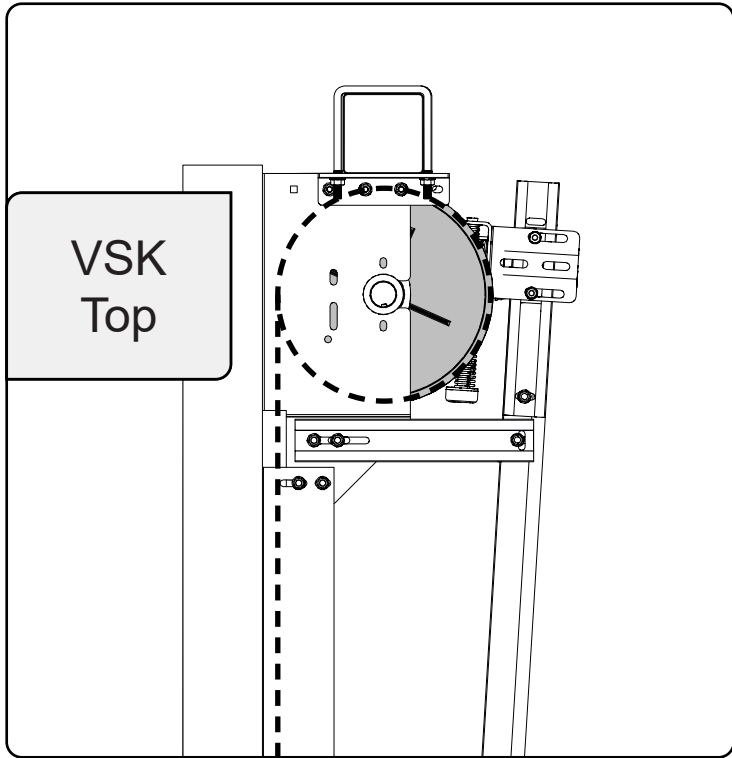
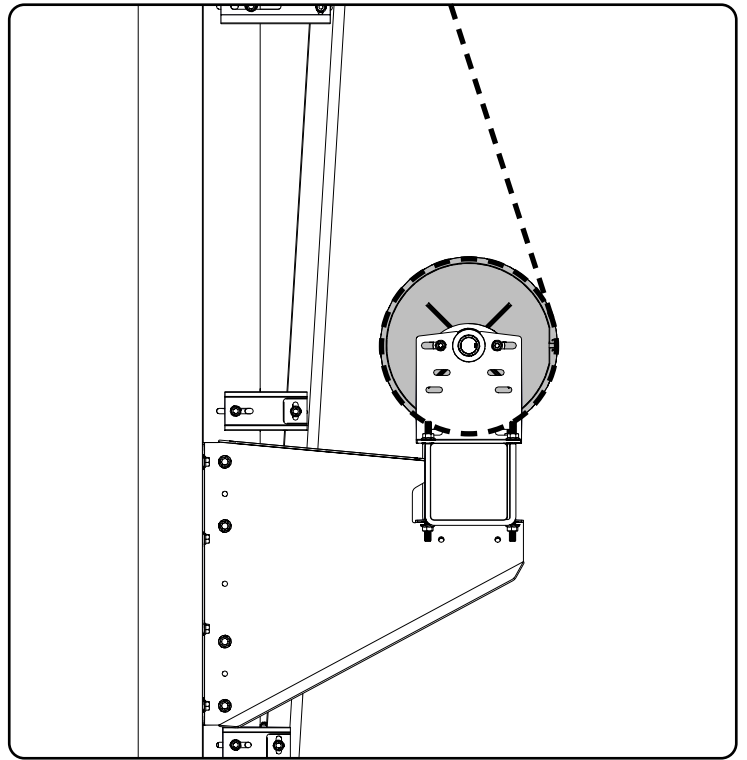
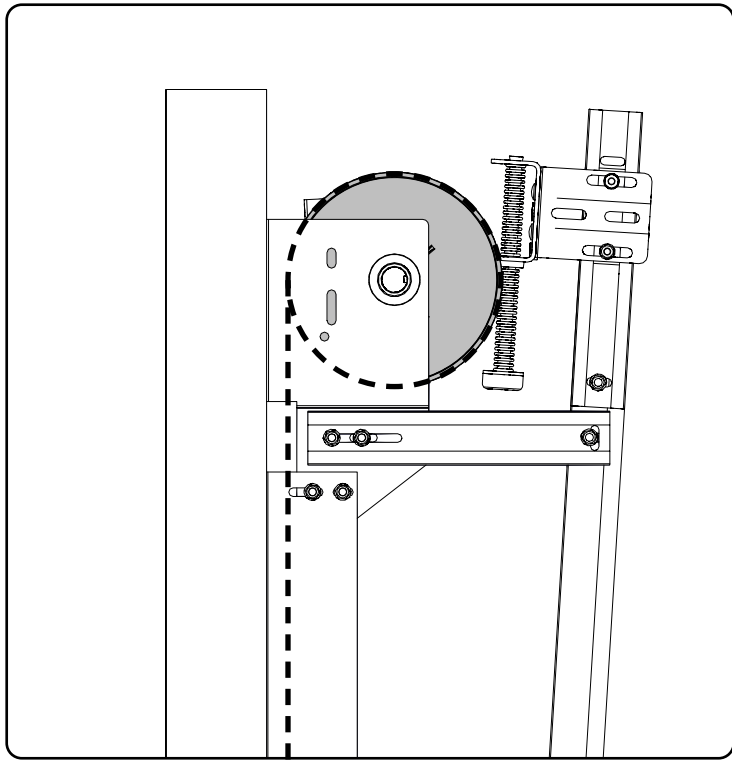

Turns x 360°

PW 12 Bon Hardware Industrie

Pitch 0 Hilift 0

E

Aant Deurtype DMB DMH Secties Velden Beslag Gewicht Turns 11.4

Klant
Klant referentie:
Transport



Aant	Eenheid	Art. nr.	Artikel omschrijving	Doos	Lengte	Verpakt / Controle
1	-		Springs Left 6,00x51x950 Powdercoated			<input type="checkbox"/> <input type="checkbox"/>
1	-		Springs Right 6,00x51x950 Powdercoated			<input type="checkbox"/> <input type="checkbox"/>

VEER / FEDER / SPRING / RESSORT < 152 mm

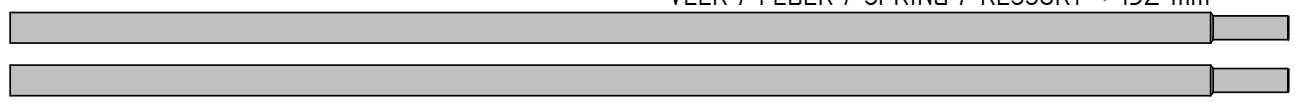

VEER / FEDER / SPRING / RESSORT < 67 mm

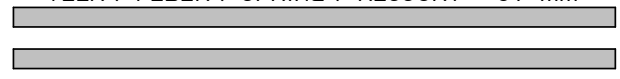

STAAL / STAHL / STEEL / ACIER 52

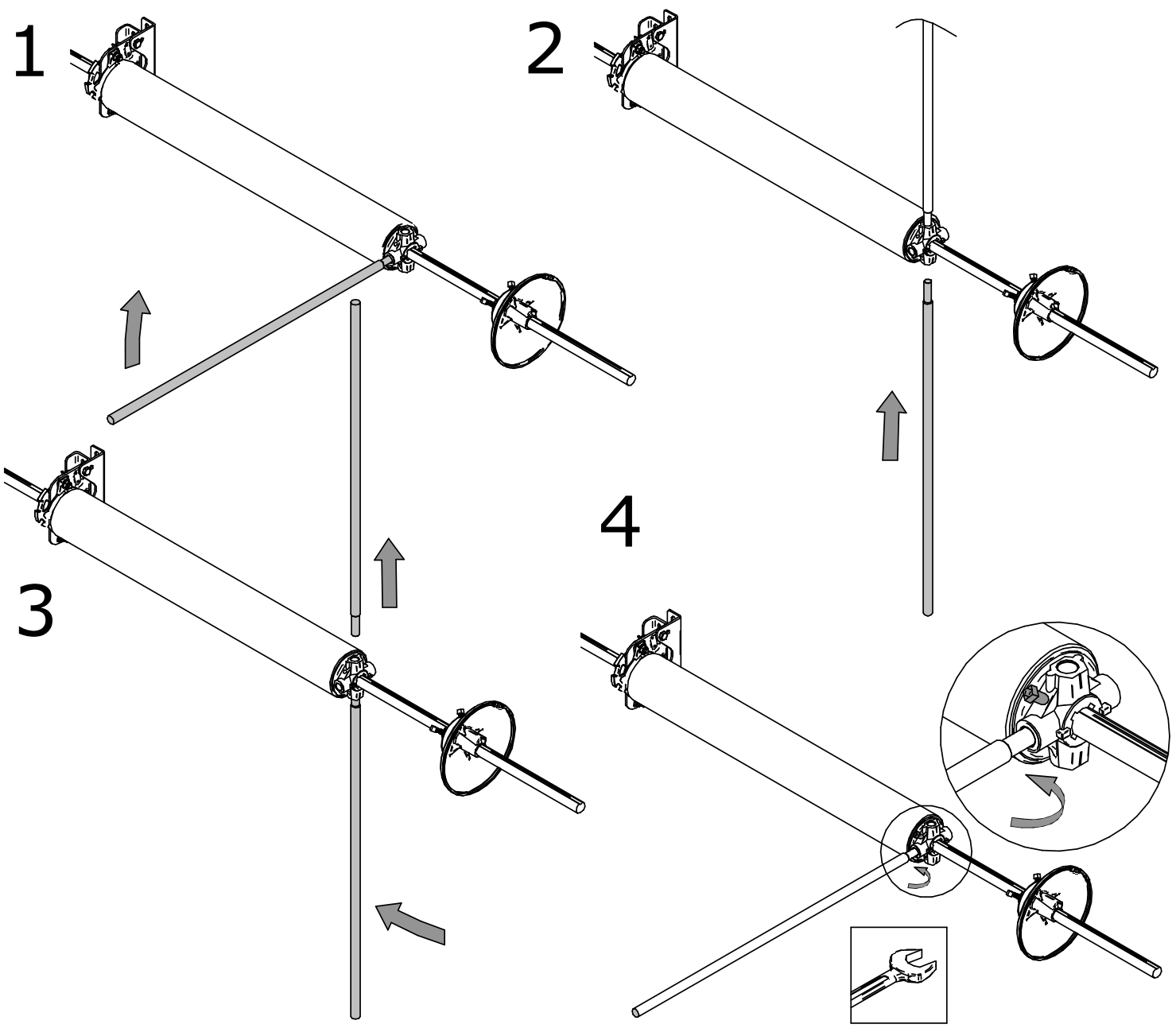

NL: Correcte wijze vastzetten van spankop
EN: Correct fastening of winding plug
DE: Richtige montage Feder spannkopf
FR: Fixation correcte du mandrin de tension

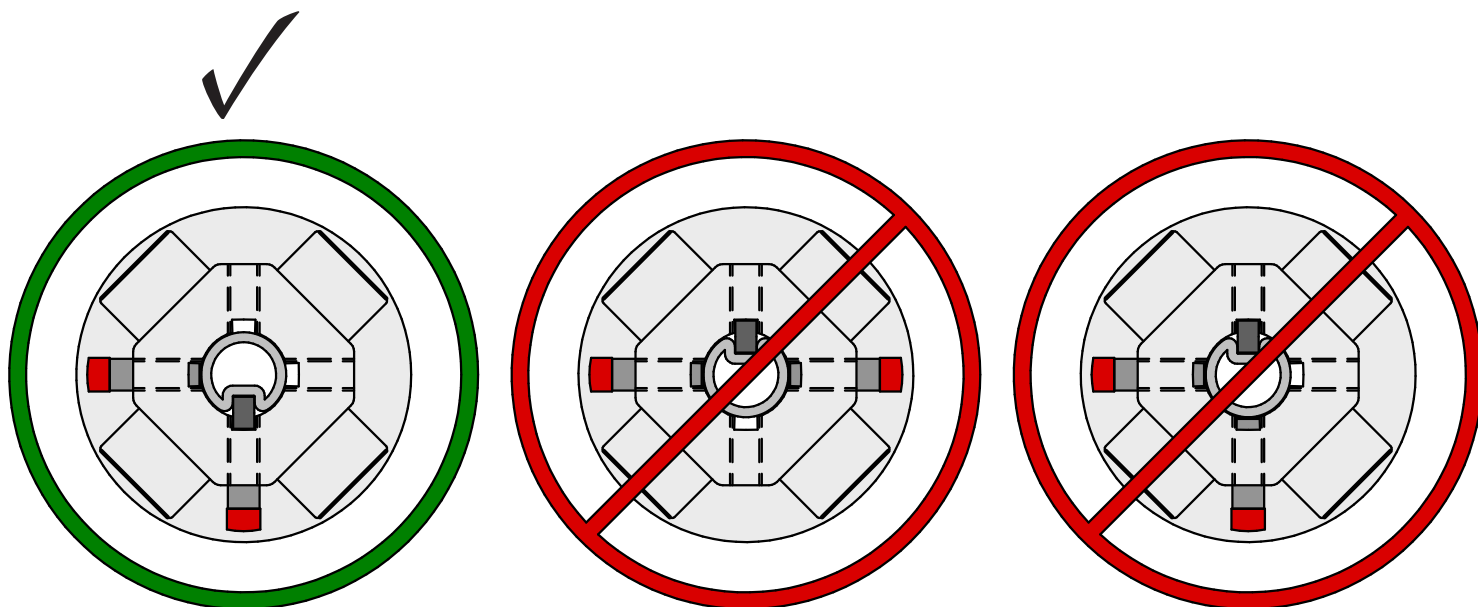

NL: Correcte wijze vastzetten van DUPLEX spankop
EN: Correct fastening of DUPLEX winding plug
DE: Richtige montage DUPLEX Feder spannkopf
FR: Fixation correcte du mandrin de tension DUPLEX

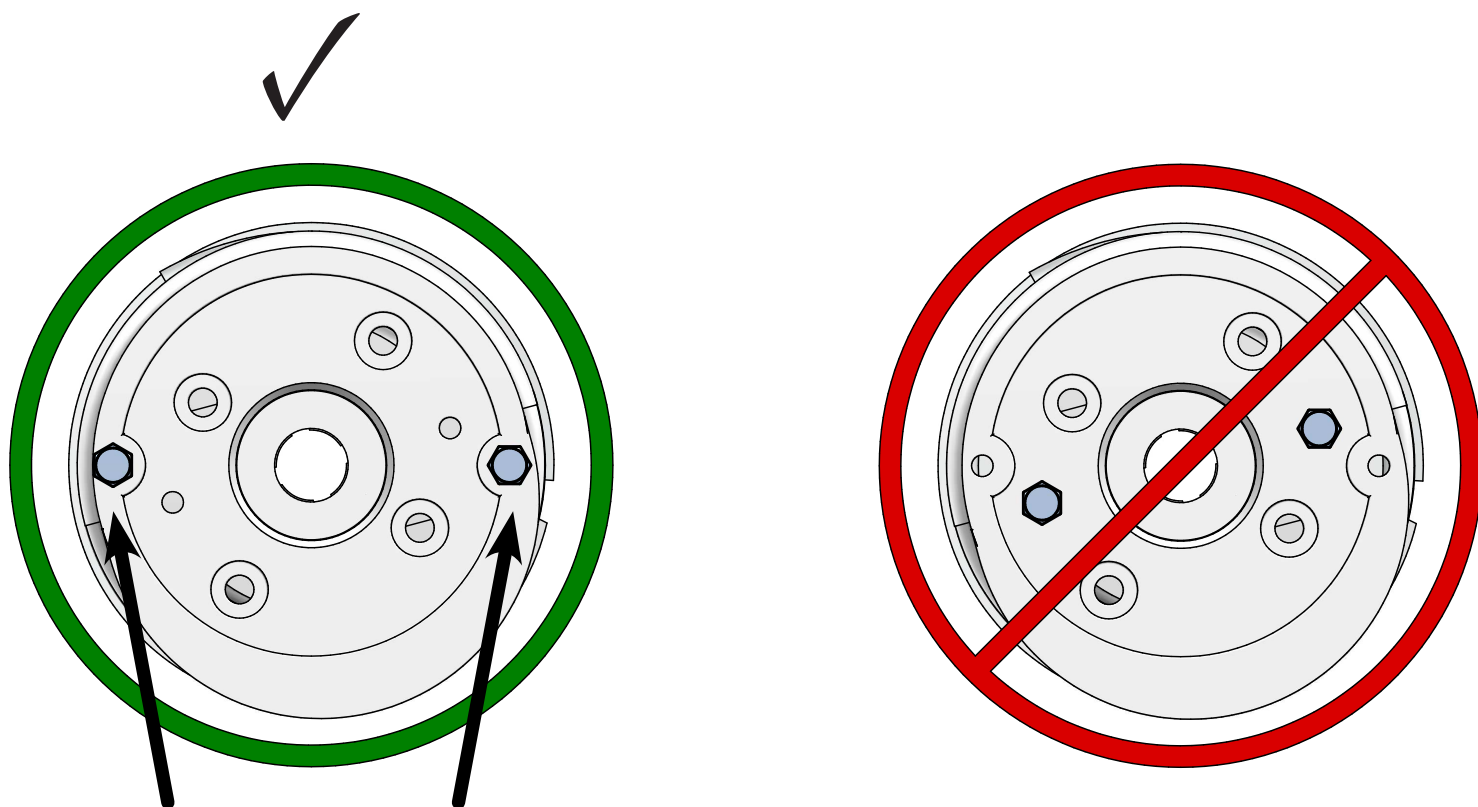

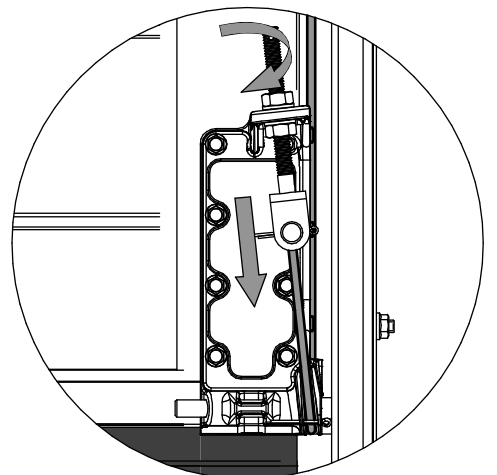
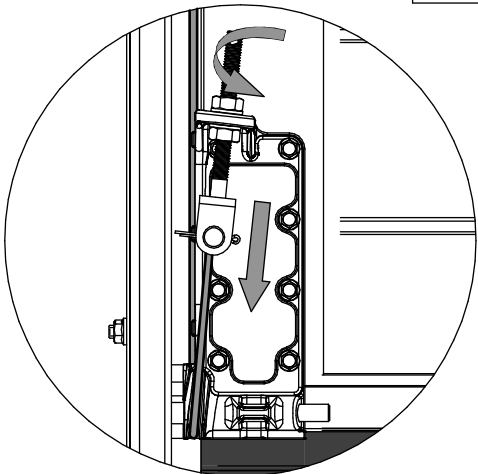
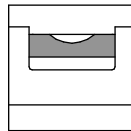
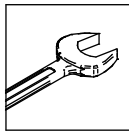
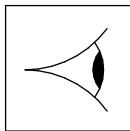
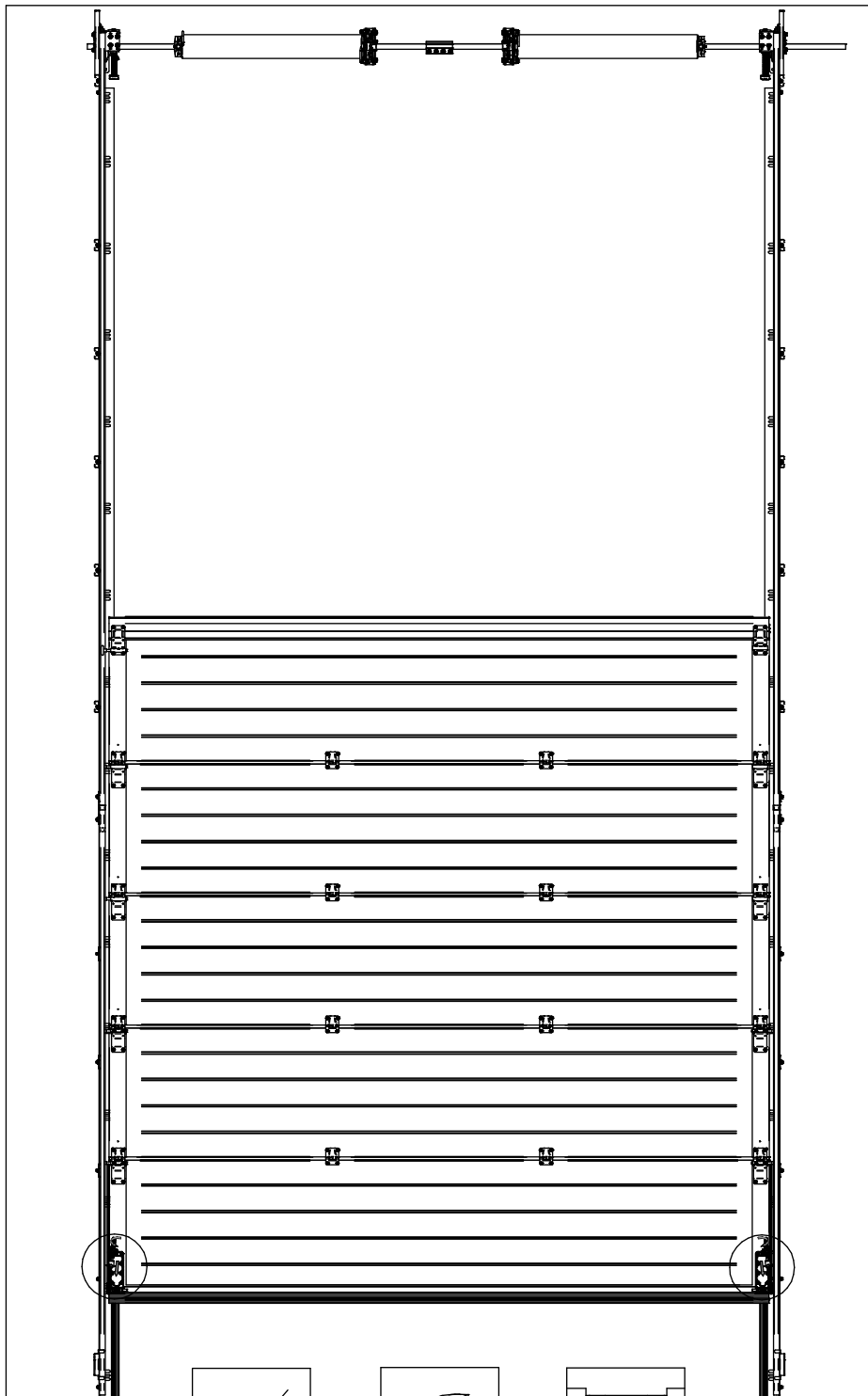

Option / Optie

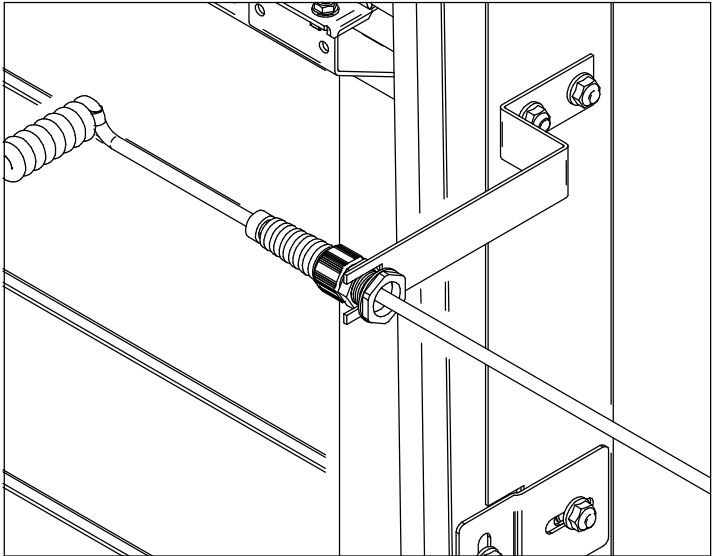
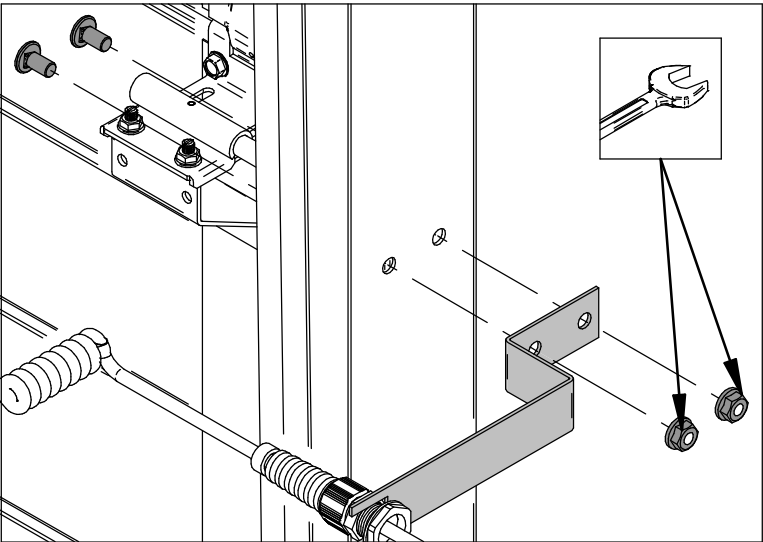
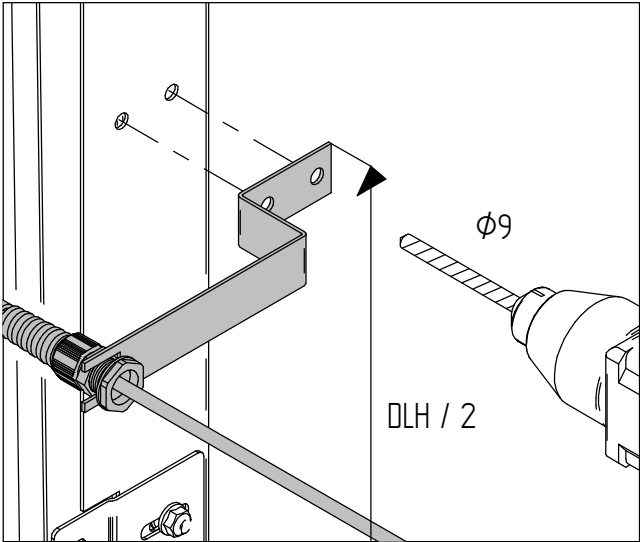
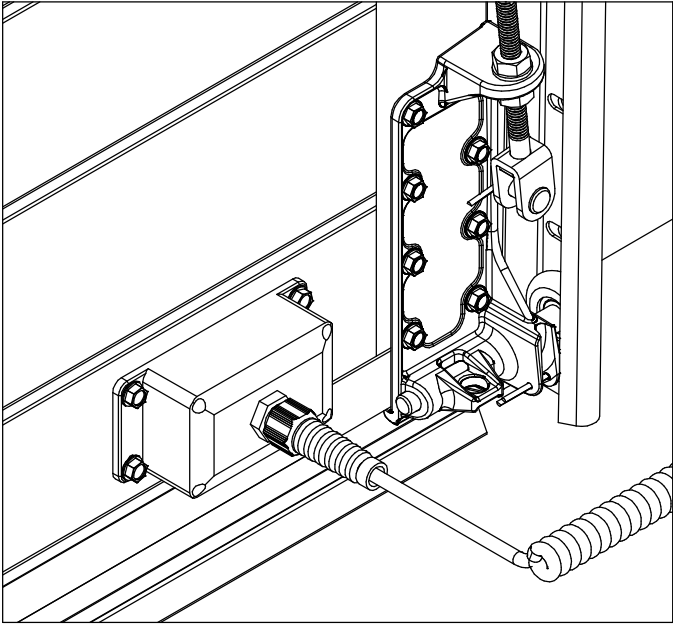
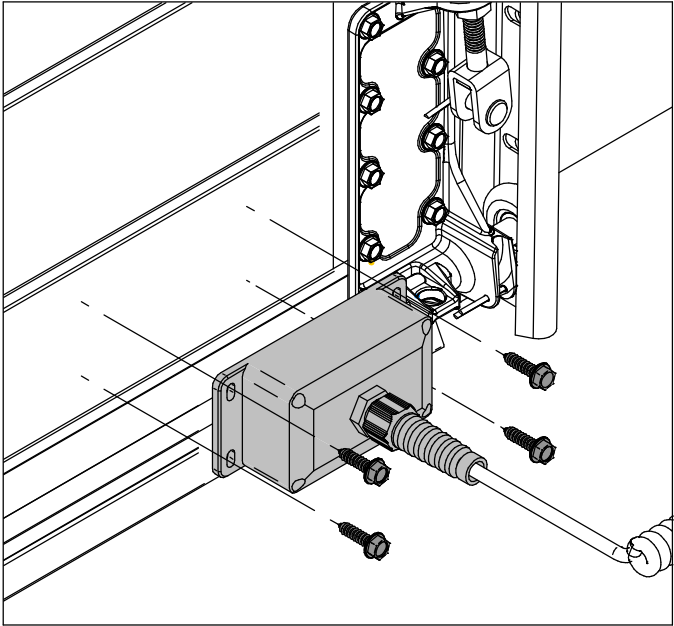

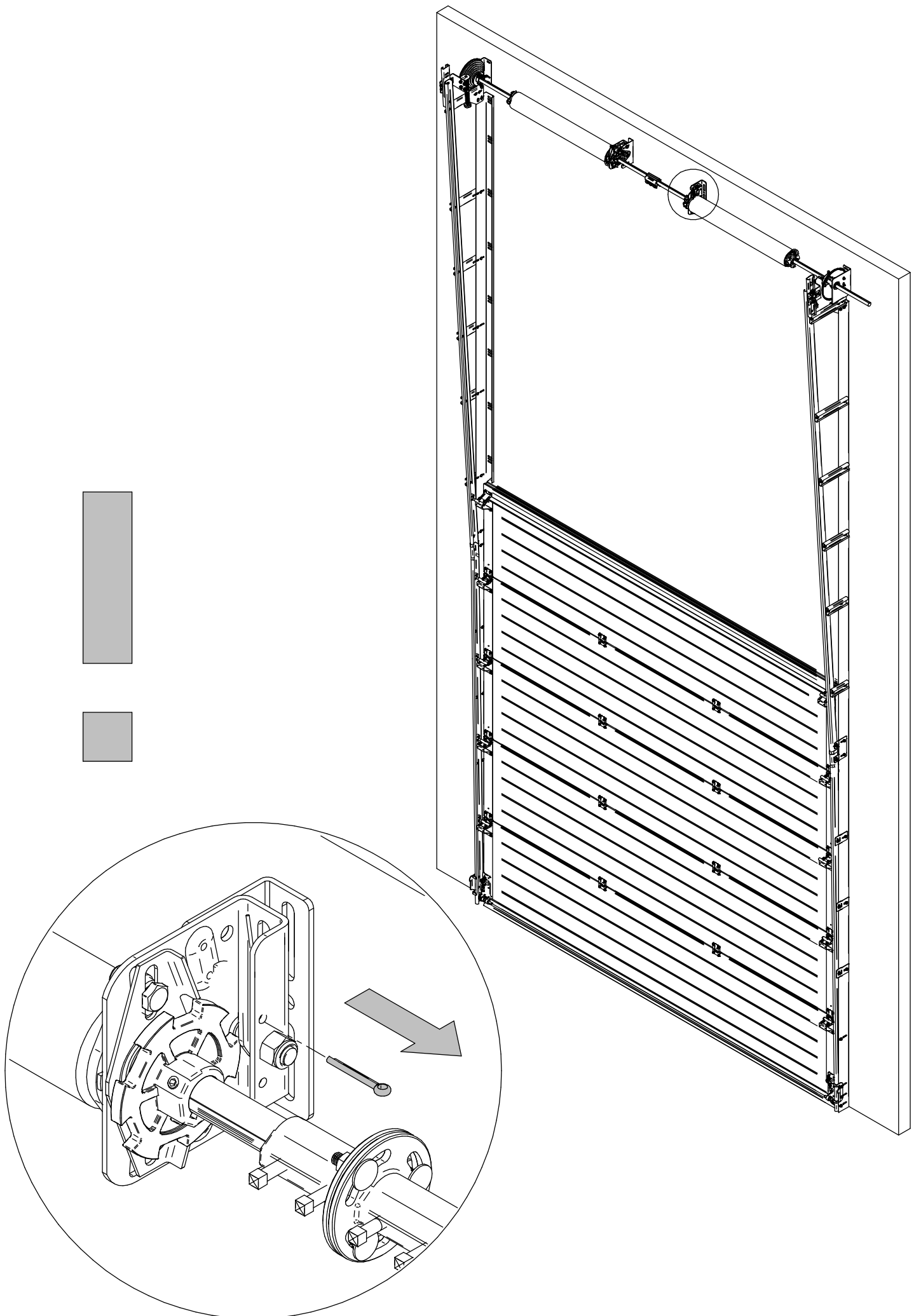

Option / Optie

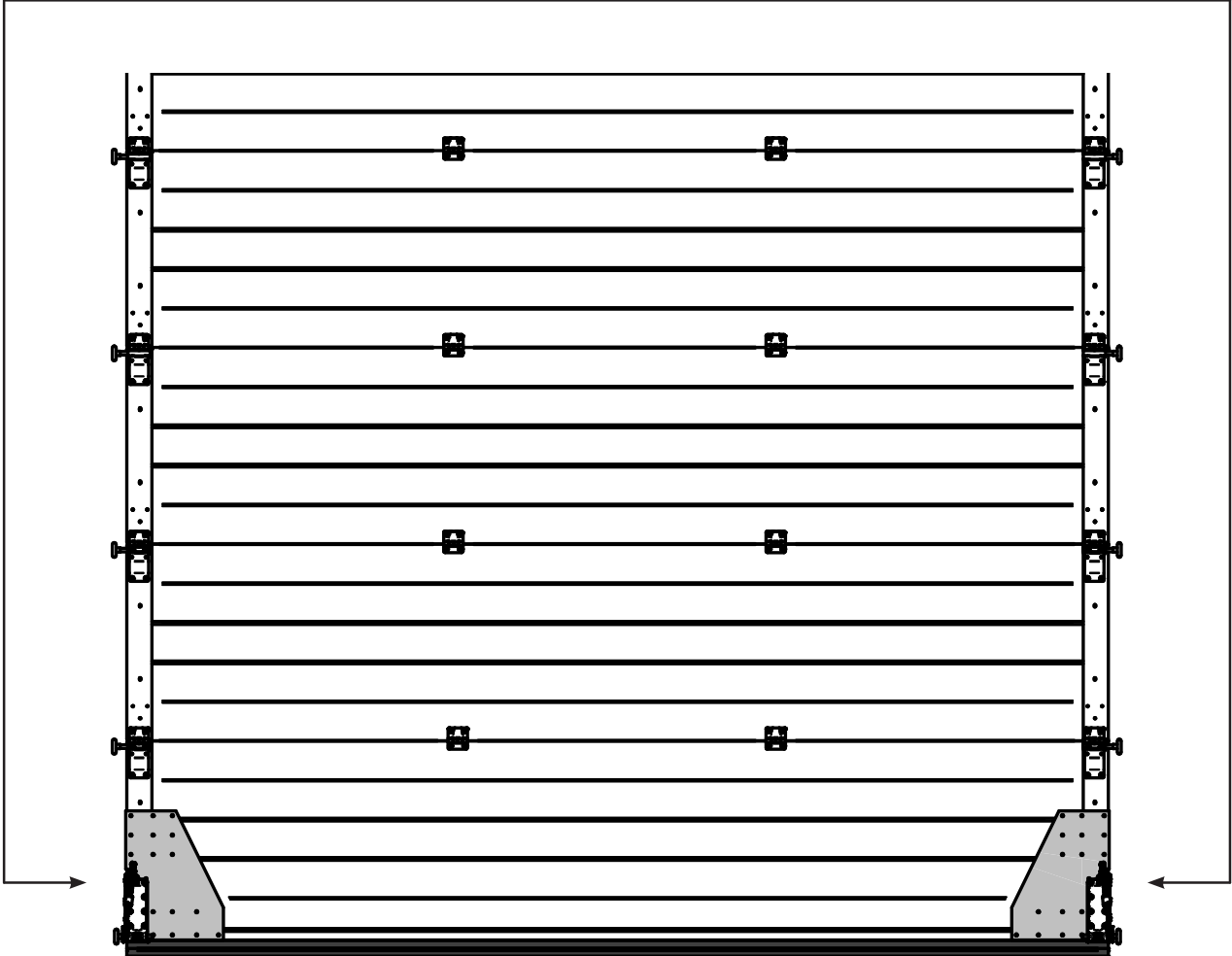
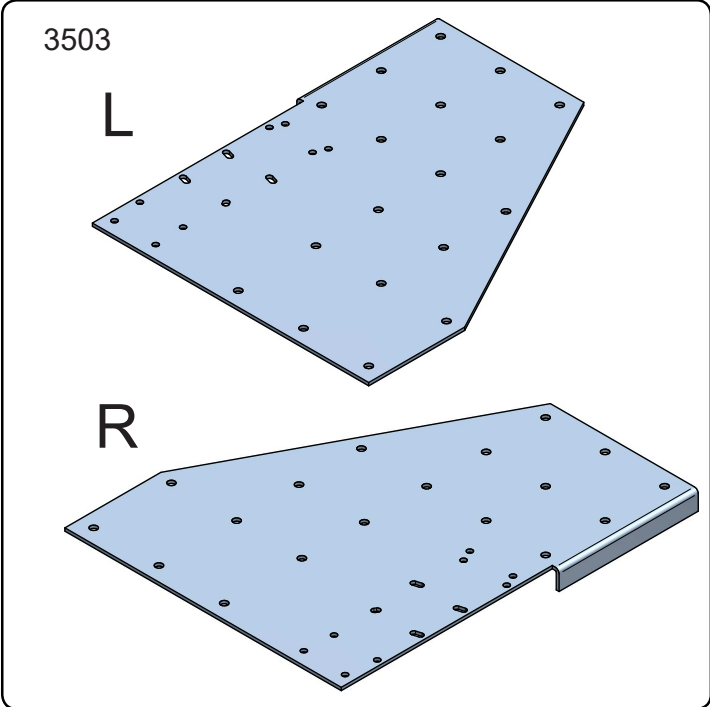
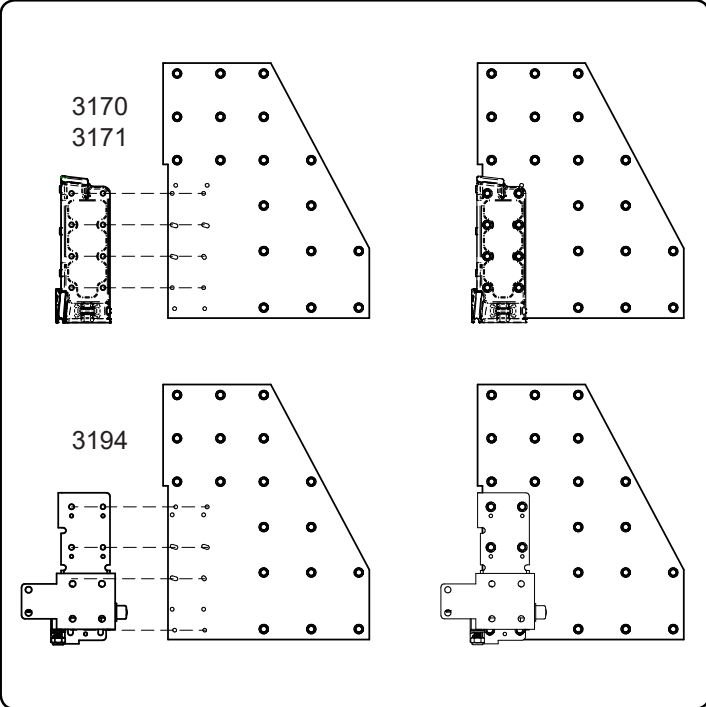

Option / Optie

3639

3812

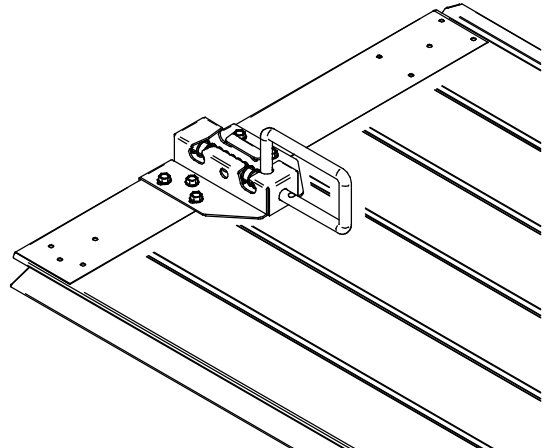
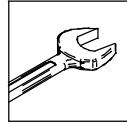
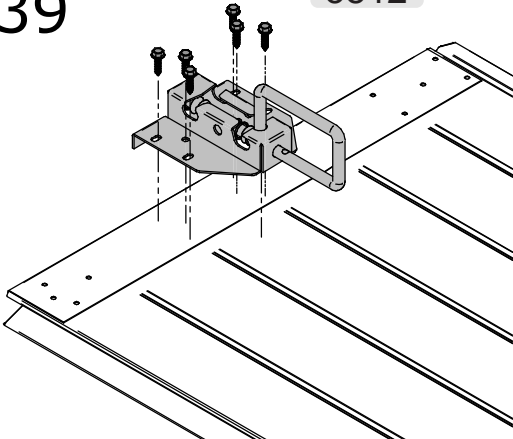

3640

3812

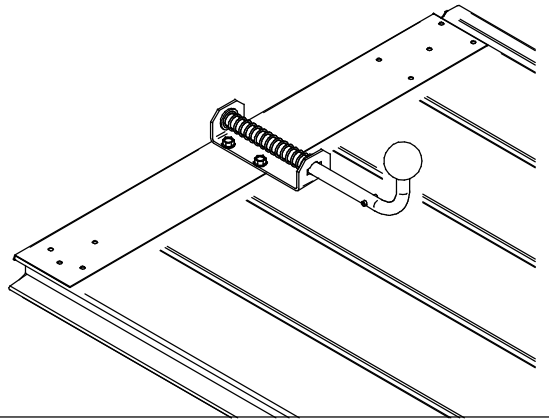
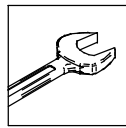
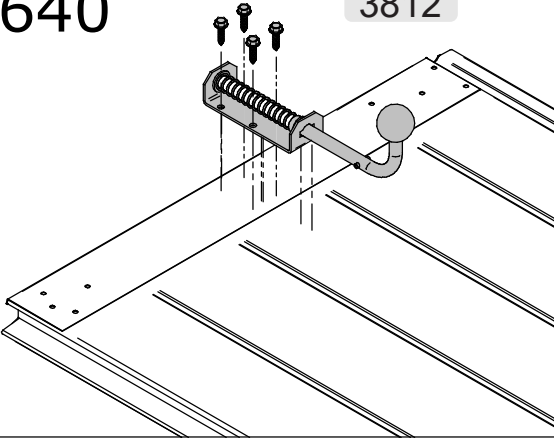

3850

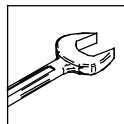
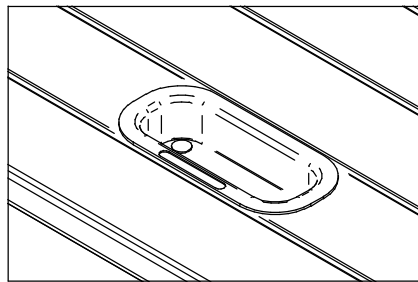
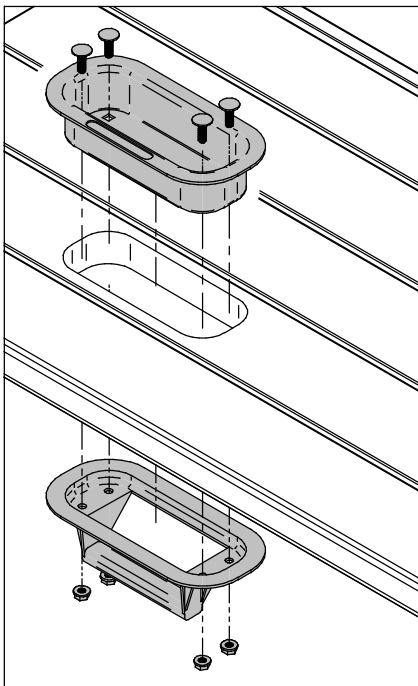

4x

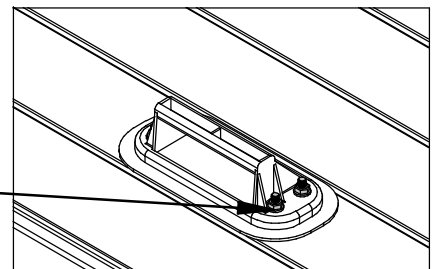

Option / Optie SCD

Parts

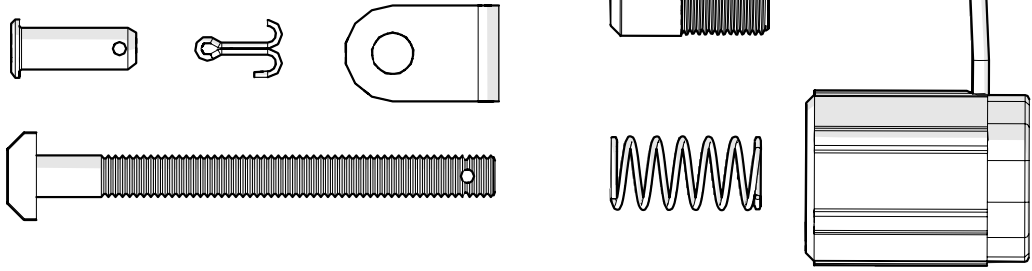

1

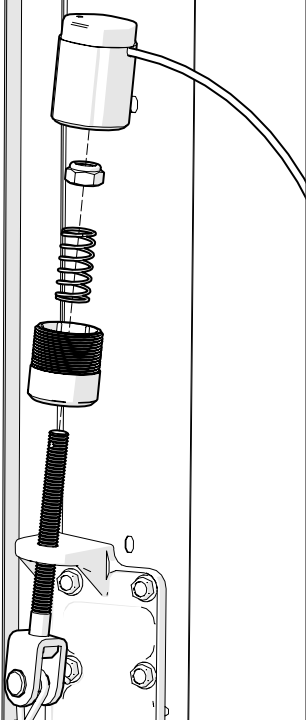

2

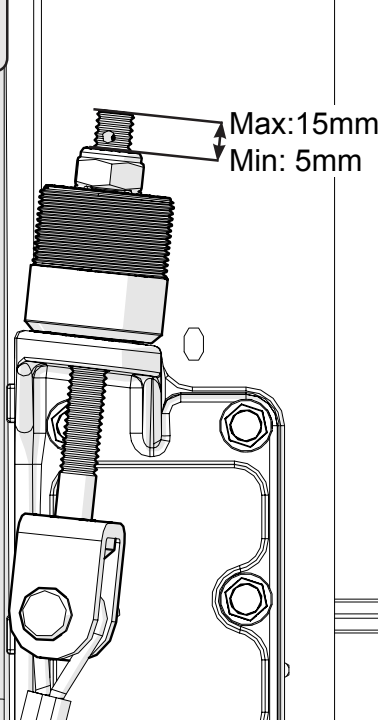

3

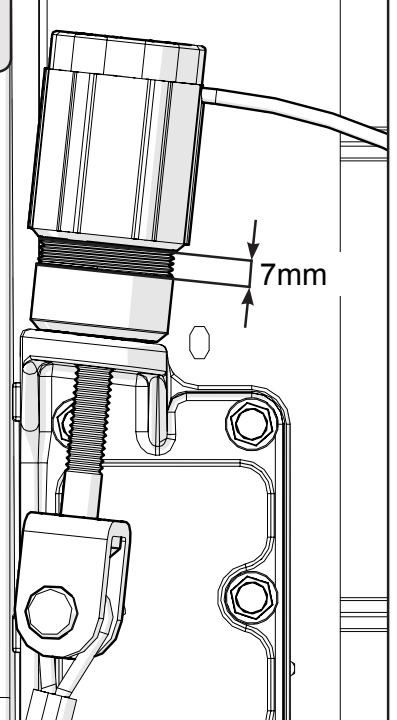

Check

NC-Switch

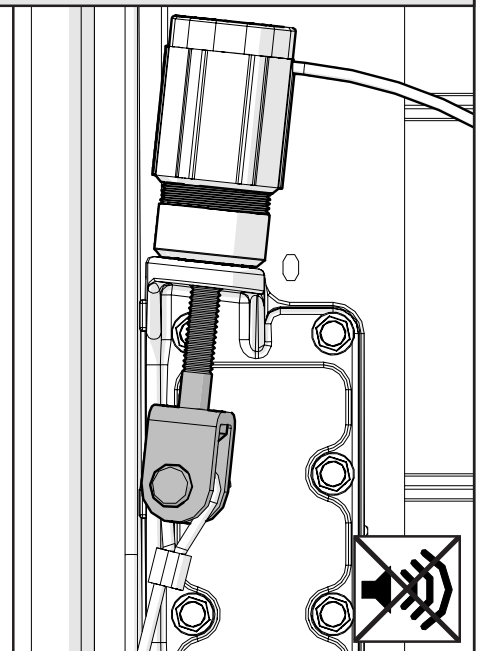
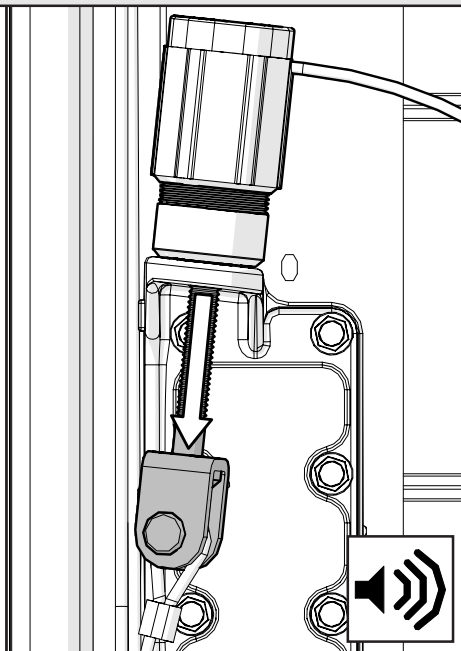
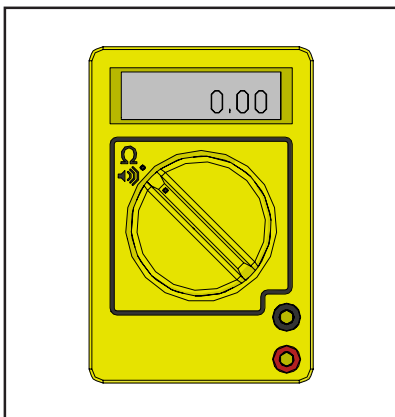

Option / Optie

5363r2

NL: Montagehandleiding Lichtlijst NS/HS/VS

EN: Assembly manual Light curtain NL/HL/VL

DE: Montageanleitung Lichtgitter NS/HS/VS

FR: Manuel de montage Barrières immatérielles de sécurité LN/LH/LV

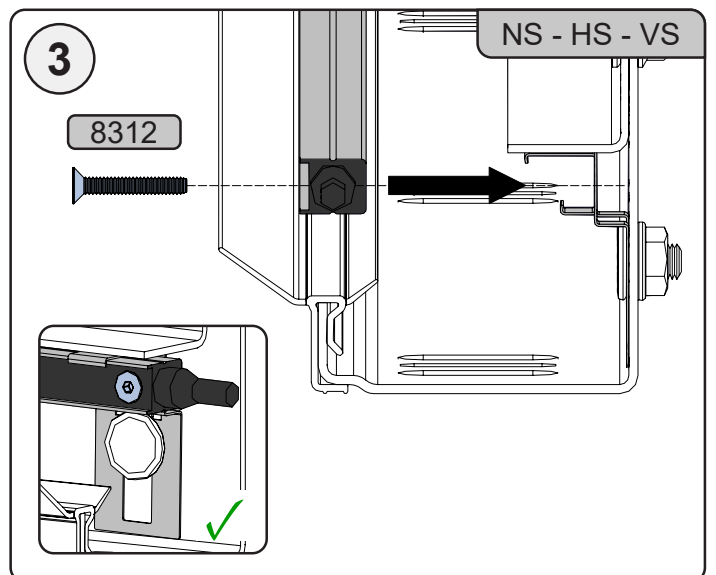
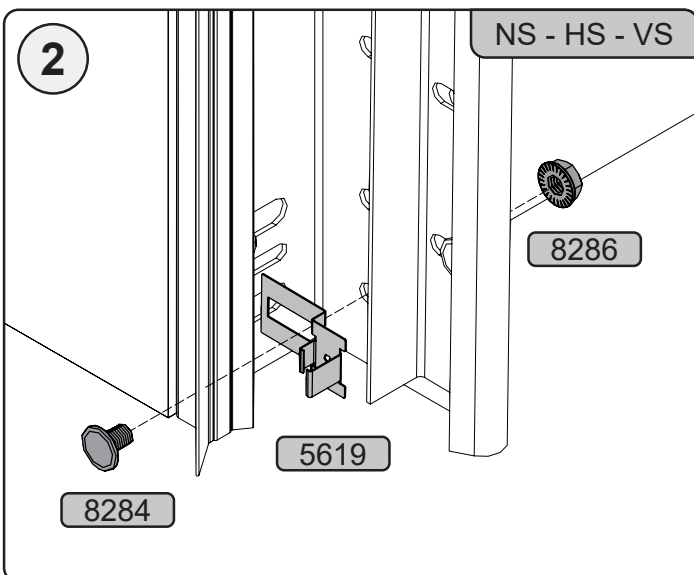
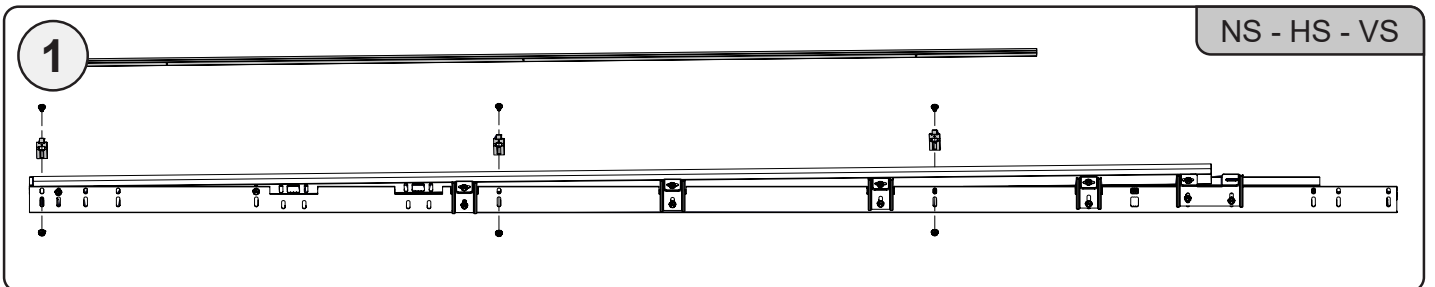
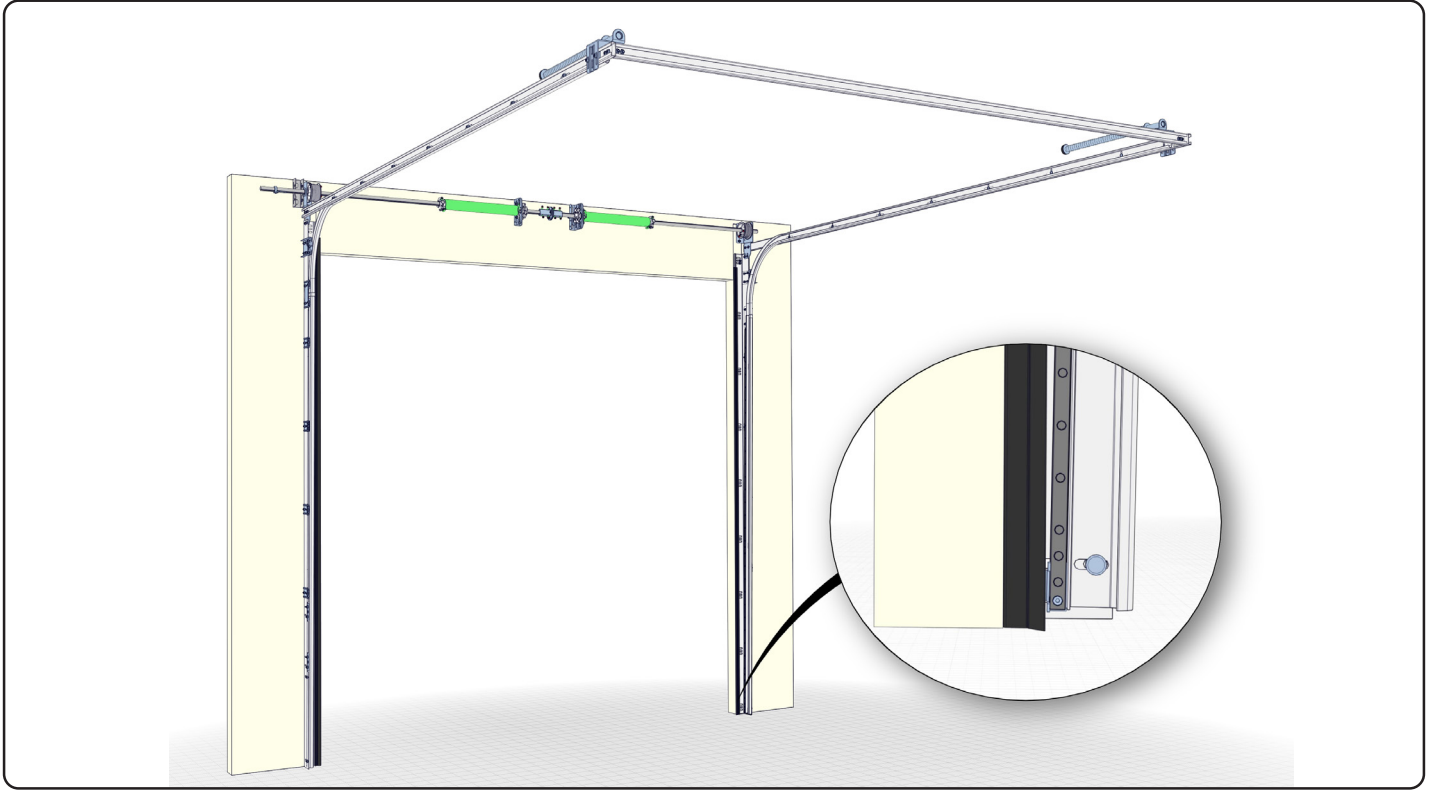

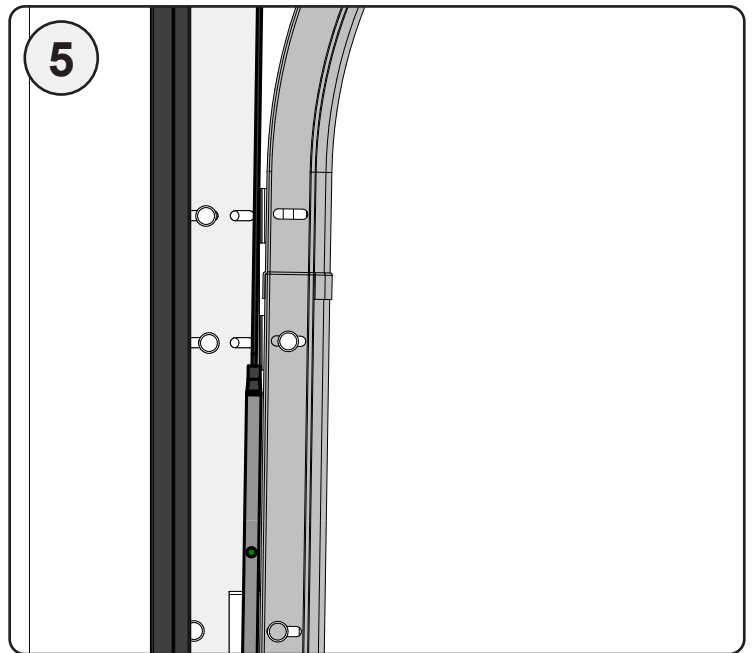
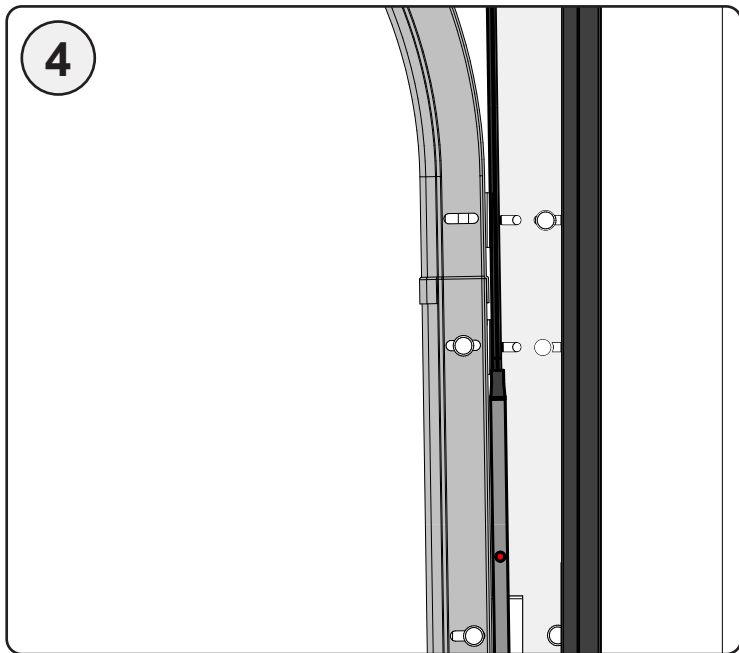
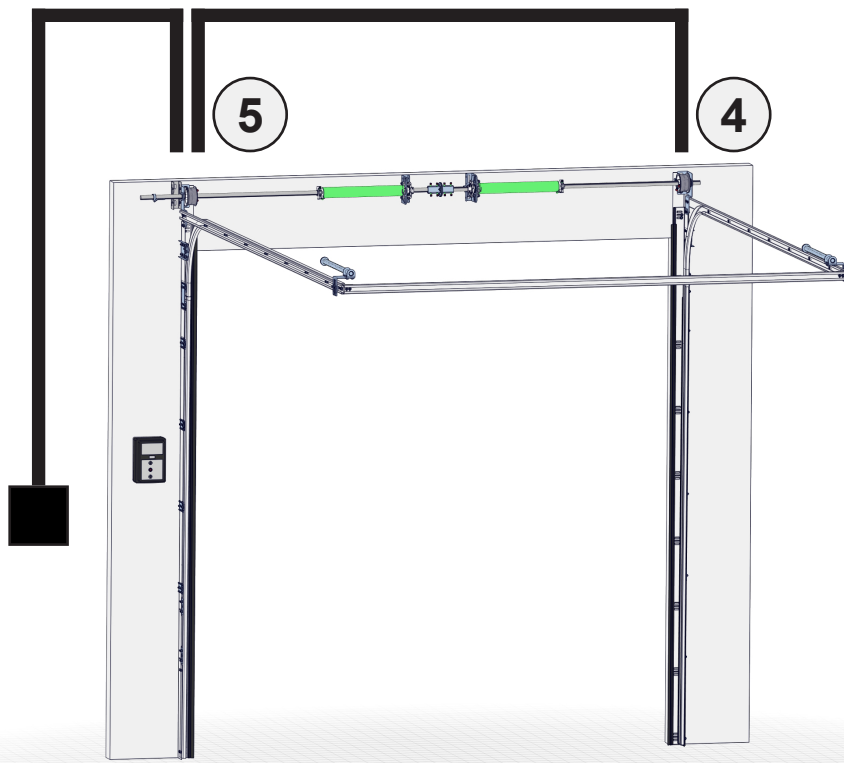

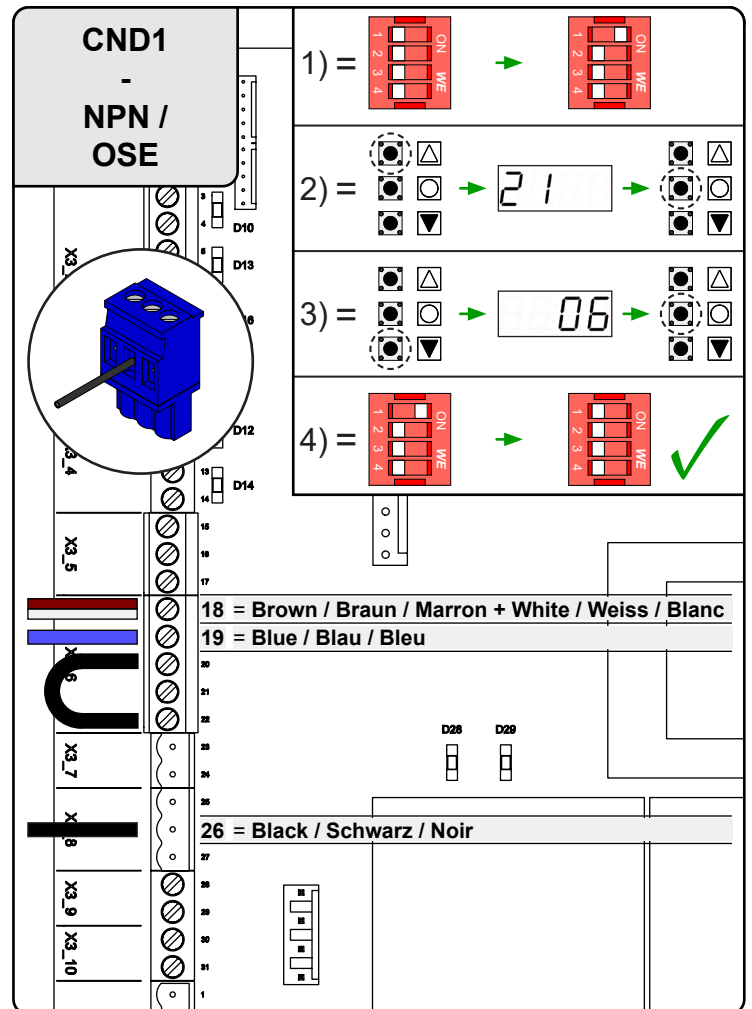
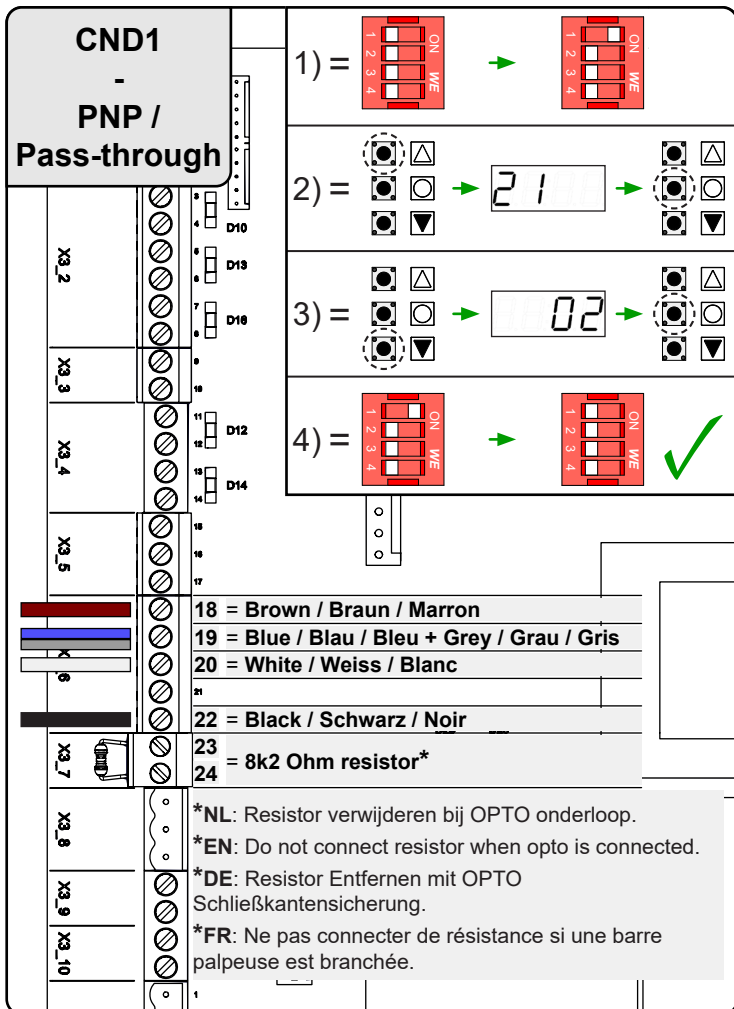
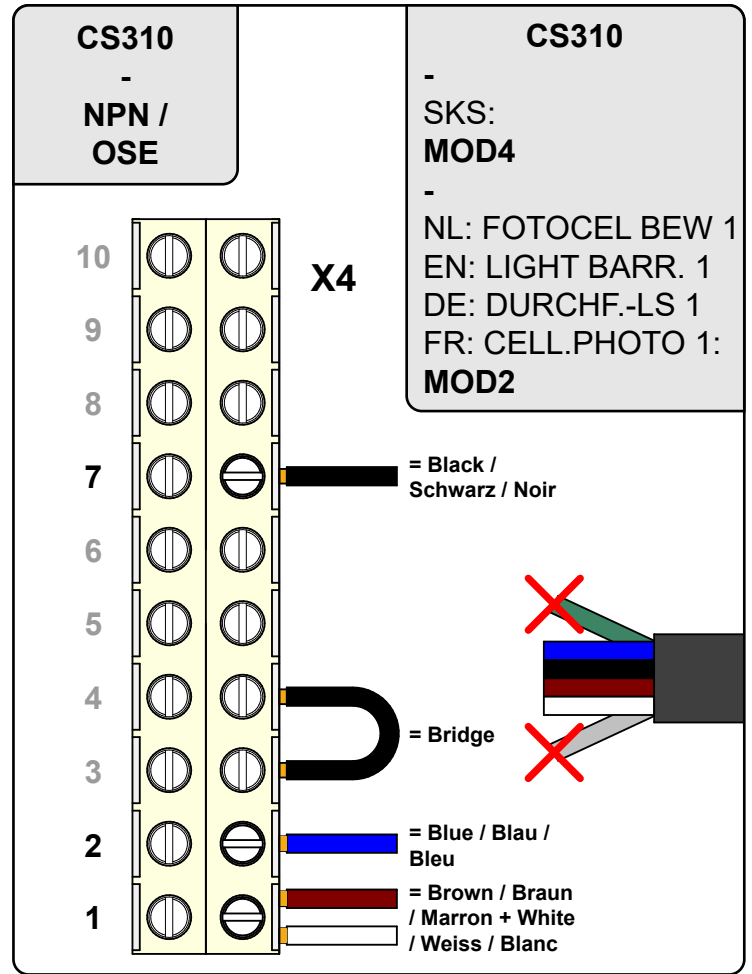
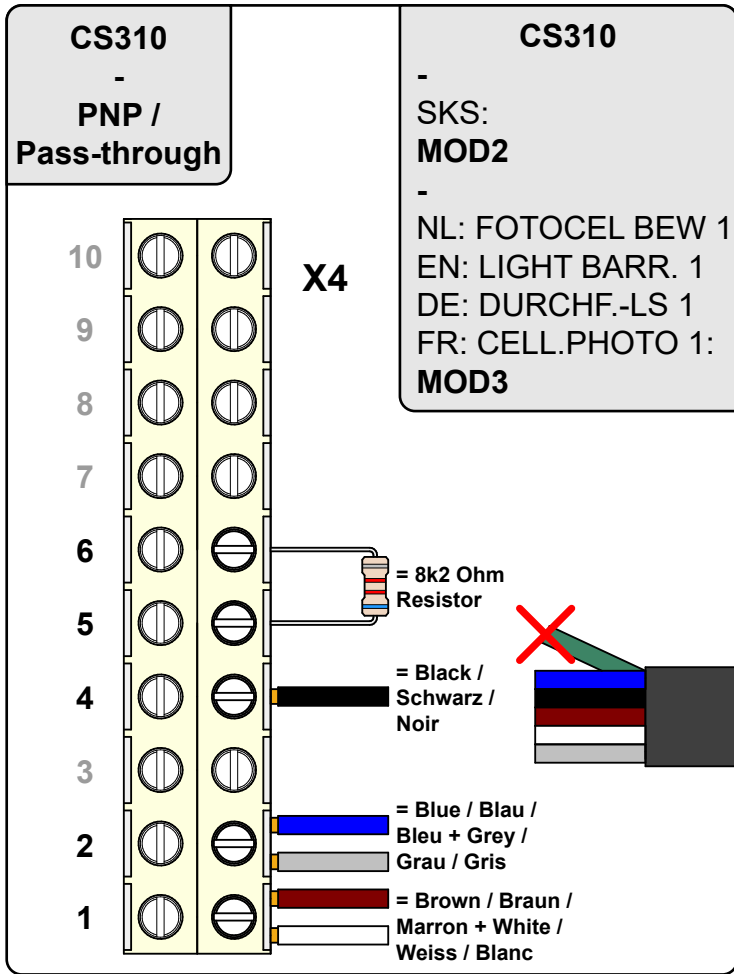

Option VA insulator 9607

